

28/29

Aug/Sept
1985

elektor

INDIA

Rs. 15.00

electronics

incorporating **selex**

**Circuits
Special 1985**
more than 100
practical projects

Suresh Singh



news views people	8-18
market	9-23
switch board	9-31
advertisers index	9-38
missing link	9-38
component sources	9-38

selex 4

digit-course (chapter 4)	9-07
radar	9-10
4.5V battery eliminator	9-12
computer tomography	9-14
batteries in series connection	9-17
dry battery charger	9-18
experiments with batteries	9-19
components	9-21
testing batteries with an ammeter	9-22

Circuits for:

audio, music, & sound generation

audio transfer equalizer	8-49
blow that synthesizer!	9-03
discomixer	8-61
heat sink monitor	8-84
hi-fi headphone amplifier	8-78
loudspeaker protection	8-65
melodic sawtooth	8-32
microphone pre-amplifier with mute switch	8-25
mini-amplifier	8-83
MOSFET power amplifier	8-96
sound-level indicator	8-40
swell pedal	8-76
wah-wah box for guitars	8-87

cars & bicycles

automatic car alarm	9-01
bicycle lights and alarm	8-31
brake lights monitor	8-73
garage stop light	9-01

computers & microprocessors

6502 tracer	8-85
current loop for modem	8-71
direct reading digitizer	8-60
faultfinding probe for μ Ps	8-47
floppy centring unit	8-82
floppy disk drive	8-67
hexadecimal keyboard	8-86
mains interface	8-75
measuring with the BBC micro	8-44
morse training with the Junior Computer	8-54
QL RAM extension	8-54
RS232 interface	8-56
serial line driver and receiver	8-21
simple video inverter for ZX81	8-51
sync inverter for QL	8-71
twin keyboard for Apple II	9-02
two-frequency clock	8-78

design ideas

combining digital circuits	8-80
designing a low noise amplifier	8-70
fast opto-coupler	8-66
fast opto-isolator	8-98
power supply sequencing for opamps	8-58
thrifty LED indicator	8-46
time-lapse unit	8-37
time stretcher	8-99

generators & oscillators

noise generator	8-72
programmable baud-rate generator	8-48
rectangular pulse generator	8-52
two-frequency oscillator	9-00

hobby & games

absorption-type metal detector	8-53
digital joystick interface	9-05
discomixer	8-61
electronic dog	8-23
infra-red light barrier	8-32
jumbo displays	8-88
LED direction indicator	8-97

contents

metal detector	8-35
miniature running lights	8-23
model aircraft monitor	8-56
model railway monitor panel	8-94
"on the air" indicator	8-97
set pointer	8-95
time-lapse unit	8-37

home & garden

automatic sliding door	9-04
burglar deterrent	8-27
CH-boiler control	8-28
flashing light with twilight switch	8-93
four position touch dimmer	8-50
hotel switch	8-32
infra-red light barrier	8-97
LED direction indicator	8-72
mains voltage monitor	8-59
mains wiring locator	8-28
metal-pipe detector	8-95
set pointer	8-27
siren	8-75
smoke and gas detector	8-43
temperature regulator with zero crossing switch	8-29
temperature sensor	8-40
twin bell-push	8-99
twin dimmer	8-34
water diverter	8-34

power supplies, batter chargers, & ancillaries

12 V NiCd battery charger	8-30
active rectifier without diodes	8-66
battery charging indicator	8-39
battery fitness centre	8-20
DC/DC converter	8-22
direct-voltage doubler	8-82
economical power supply	8-43
heat sink monitor	8-84
lead-acid battery charger	8-73
mains interface	8-75
mains power supply with primary regulation	8-20
mains voltage monitor	8-72
negative supply converter	8-34
simple zero crossing detector	8-69
variable 3 A power supply	8-84

RF & video

electronic VHF/UHF aerial switch	8-48
morse training with the Junior computer	8-54
NAVTEX receiver	8-44
RTTY calibration indicator	8-46
RTTY/CW filter	8-36
send-receive ident	8-79
simple field strength indicator	8-66
simple video inverter for ZX81	8-51
spot frequency receiver	8-77
sync separator	8-93
video amplifier for B/W television sets	8-98
video buffer/repeater	8-21
video distribution amplifier	8-81
video selector	8-70
VLF converter	8-58

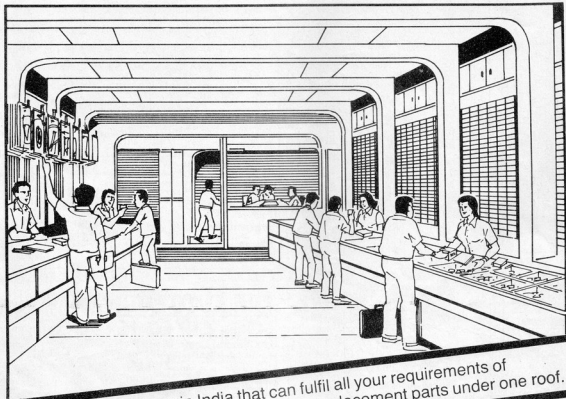
test & measurement

audio tester	8-68
automatic switch off	8-59
crystal tester	8-38
faultfinding probe for μ Ps	8-47
GHz prescaler	9-06
measuring with the BBC micro	8-44
meter amplifier	8-45
metering selector	8-39
noise generator	8-72
opamp tester	8-37
RTTY calibrator indicator	8-46
simplified word comparator	8-36

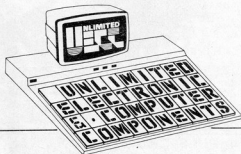
UNLIMITED

Electronic and Computer Components

UNLIMITED is the only word that can correctly describe the range of components available at our new showroom!



The largest showroom in India that can fulfil all your requirements of Electronic & Computer Components and replacement parts under one roof.



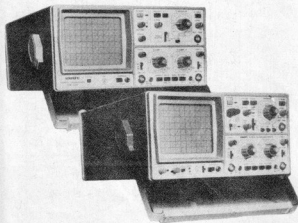
PCBs and Components
for ELEKTOR Projects
are also available with us.

UNLIMITED Electronic & Computer Components

Neelam Manzil, 1st Floor,
350, Lamington Road,
Bombay 400 007
Phone: C/o. 384634

Two New Numbers
to Remember !

HM 203
HM 204



Scientific announces two new additions to its trusted and time-proven range of HM Series Oscilloscopes: HM 203 and HM 204 Dual Trace 20 MHz Oscilloscopes. These sleek new low-line portables incorporate the latest in international product design and features: a 140 mm rectangular flat-face CRT with illuminated internal graticule, 8 x 10 cm display, high 2 mV sensitivity and 20 MHz bandwidth, HF triggering up to 50 MHz, single touch component tester, sweep delay, and many more features never before available in this price range.

So remember HM 203 and HM 204, when you order an oscilloscope next. You will be glad you did.

scientific the affordable
portables !

Manufactured by:

SCIENTIFIC MES-TECHNIK PVT. LTD.

Formerly known as: SCIENTIFIC INSTRUMENTS (INDORE) PVT. LTD.

B-14, Pologround, Industrial Estate, Indore 452 003

Telephone: 31777, 31778; Cable: SCOPE, Telex: 0735-267

Customer Services at :

Bombay, Bangalore, Calcutta, Delhi, Hyderabad, Madras.

**MACMILLAN OFFERS YOU
BOOKS ON EVERY ASPECT OF
COMPUTER SCIENCE**

Programming & Problem-Solving in Algol 68-Colin	£ 7.95
Fundamentals of Computer Science - Colin	£ 7.50
Introduction to Numerical Computation in Pascal - Dew & James	£ 9.95
From Hardware to Software : An Introduction to Computers - Graham Lee	£ 9.95
Fundamentals of Operating Systems - A M Lister	£ 7.50
L I S P - Different Sort Language - Queinnee	£ 6.95
F O R T H - Salman & Tisserand	£ 7.95
A Practical Course on Operating Systems - Theaker & Brooks	£ 7.50
A Practical Introduction to Pascal - with BS 6192 - Wilson & Addyman	£ 6.95

Fundamentals of Modern Digital Systems - Bannister	£ 8.50
A Handbook of Systems Analysis - Bingham & Davies	£ 7.50
Assembly Language Programming for the B C Microcomputer Birnbaum	£ 8.95
Advanced Programming for the 16K ZX81 - Costello	£ 5.95
Beginning Basic - Gosling	£ 3.95
Microprocessors & Microcomputers: their use & programming - Huggins	£ 5.95
Microprocessor & Microcomputer Technology - Morris	£ 6.95
Continuing Basic - Gosling	Rs. 35.00

MACMILLAN MASTER SERIES

Mastering Computers - G G I Wright	Rs. 44.00
Mastering Computer Programming - Gosling	Rs. 44.00
Mastering Cobol Programming - R Hutty	Rs. 44.00
Mastering Data Processing - Bingham	Rs. 44.00
Mastering Electronics - J Watson	Rs. 44.00
Mastering Pascal Programming - E Huggins	Rs. 44.00
Mastering Word Processing - P E Gosling	Rs. 44.00

contact: **M**

MACMILLAN INDIA LTD.

Mercantile House Magazine Street, Reay Road (E)

Bombay - 400 010 Phone No. : 8515394/8515396/8515401

THE AUTO LOGIC MONITOR

LOGICCLIP LC-16
16 Channel Logic Monitor

- Just clip it on your IC and Logicclip instantly and accurately shows both static and dynamic logic states on a bright 16-LED display
- As it finds its own power no need to make supply/ground connections or keep your hands occupied
- Simultaneous monitoring of all 16 pins cuts out guess work, saves time and eliminates the risk of short circuits.
- LC-16 is compatible with all dual-in-line logic ICs, DTL, TTL, HTL, ECL, L, LS, S, CMOS, upto 16 pins

TECHNICAL DATA	
Logic Threshold	2 volts ± 2 volts
Input Impedance	100,000 ohms
Input Voltage Range	0 to 5V
Power	10 mW maximum
Probe lead type	40 wire snap pins
Maximum Input Frequency	100 MHz (DC, 200 kHz AC)
Operating Temperature	0° to 50° C
Storage	0 to 50° C
Dimensions in case	100 x 1.5 x 60 x 40 mm

*Note: DC when input signals are not observed except by 50 Ω

Try the LC-16
and you will
wonder
how you ever
managed
without it!

- Applications:**
- Design, Breadboarding, testing and checking new logic systems
 - Production testing and servicing aid
 - Direct real time monitoring of logic function in operating equipment
 - Monitoring of individual IC
 - Identification of crused elements in given IC
- To find the relationship between two or more ICs on different boards by using two or more LC-16
- Plus many more uses for you to find



Now with
imported
contact
clip.

Only Rs. 885/-

also available
with banking, forwarding, etc. 20%
discount when you send international
order accompanied by V.P.P.

Quantity available from all cities welcome



PULSECHO SYSTEMS

107, Normal Industrial Estate, Near Sion Fort,

Road No. 29, Sion (East), Bombay - 400 022, INDIA.

Telephone: 47 10 55 48 20 87

Gram: 'PULSECHO' Matunga, Bombay - 400 019.

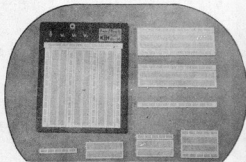
Telex/C/o: -011-71447 (MDEV:IN)

TARGET

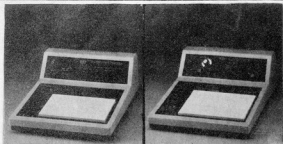
Device offers



**ELECTRONIC
EDUCATIONAL
& TESTING
DEVICES**



Solderless Bread Board



1 DL-400 Logic Trainer

1 DL-800 Digital Lab



1 DL-600 Analog Lab

DT-01 Digital Trainer

We stock:

elektor
Magazines

IC IZUMIYA IC INC.
P.C.B. Drafting Aids

TELEDYNE
RELAYS

RCA
Semiconductors

**KONTAKT
CHEMIE**
Cleaners

RAYTHEON
Semiconductors

FAIRCHILD
Semiconductors


TEXAS INSTRUMENTS
Semiconductors

VRN Trimming
INTERNATIONAL Potentiometers

Bread Boards
Metal Film Resistors

SSS
Semiconductors

Transistors
Zener Diodes

SPECIAL EX STOCK OFFER

CA 307E CA 324E CA 339E CA 555E CA 741E CA 723E CA 747E
CA 3065E CA 3068 CA 3086 2N 3055

Bulk importers and users in India may Kindly forward their specific enquiries



Device Electronics Pte. Ltd.

101 Kitchener Road *02-04, Singapore Electrical, Electronics and Hardware Centre,
Singapore 0820. Telex : DEVICE RS 33250

FOR ENQUIRIES **CALL: 298 6455** (4 lines)

SOLDRON[®]
SOLDERING IRONS

Sophisticated Design
Versatile Applications
Only of its kind in India.

NOW AVAILABLE
IN TWO MODELS.

25 Watts × 230 Volts
50 Watts × 230 Volts

Also available in
6-12-24-110 Volts.

Exclusive Features:

- Very low leakage.
- Super fast heating.
- Quick recovery.
- High efficiency.
- Light weight.
- Iron + Nickel plated bits available for longer bit life.

Bombay Insulated
Cables and Wires Co.

74, Podar Chambers,
Third floor,
S.A. Brelvi Road,
(Parsi Bazar Street)
Bombay-400 001.
Phones: 254892, 295773

ALSO AVAILABLE:



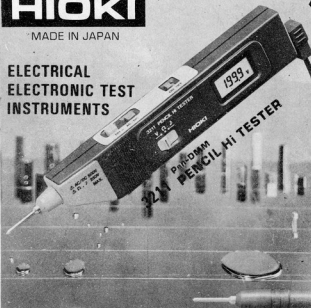
SOLDRON SOLDERING
IRON STAND.

Our new range of precision low wattage miniature soldering irons will be marketed soon.

HIOKI

MADE IN JAPAN

ELECTRICAL
ELECTRONIC TEST
INSTRUMENTS



SOLE AGENT

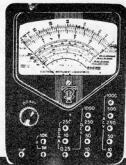


HENSON VIDOC CO., (PTE) LTD.

5001 Beach Road, # 09-16 Golden Mile Complex,
Singapore 0719, Tel 7460051, 2924993
Cable Address: HENVIDOC Telex RS 34344 VIDOC

POPULAR

TESTICA T-3



ONLY

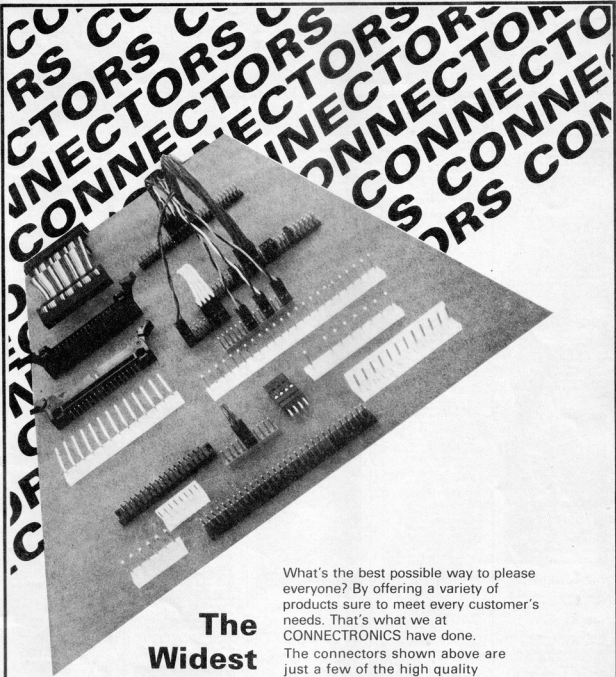
Rs 170/-

THE ONLY MULTIMETER
WITH
PROMPT SERVICE AFTER SALES
ACCURATE! ROBUST!
ECONOMICAL!

AVAILABLE AT ALL COMPONENT SHOPS

MANUFACTURERS:
ELECTRICAL INSTRUMENT
LABORATORIES,

339/68, RAJESH BUILDING, LAMINGTON ROAD,
BOMBAY-400 007. PHONE-36 07 49.



**The
Widest
Choice in
Connectors!**

What's the best possible way to please everyone? By offering a variety of products sure to meet every customer's needs. That's what we at CONNECTRONICS have done.

The connectors shown above are just a few of the high quality products we offer. Variety and quality – that's what makes CONNECTRONICS customers keep coming back.

Connectronics

Chhotani Building, 52-B, 1st Floor,
Proctor Road, Bombay 400 007
Phone: 360709

back number service

E1, May 1983

Low-power digital thermometer/MC/phone preamp/technical answers/membrane switches/interlude/RC equalizer/7-day timer/controller/Junior program-tester/prelude (part 3)/programmable dark room timer/talking-clock extension

E2, June 1983

Wattmeter/ASCII keyboard/P.S. Multimeter/Mastro (Part 1)/What is power?/parallel serial keyboard converter/morse converter/78L voltage regulators and 78L/morse decoding with the 280A.

E3, July 1983

Energy meter/switching channel for radio control/RTTY decoder/electronic aerial switch/spectrum display/mastro (Part 2)/video effect generator/morse and radio teletype RTTY/appliator.



E4/5, Aug/Sept 1983

Circuits special 83 more than 100 practical projects

E6, October 1983

Video graphics/autotest/64k on the 16k Dynamic RAM card/high-speed CMOS/VDU card/personal FM/precision voltage divider/Junior Synthesizer/simple MOSFET tester/the stamp

E7, November 1983

Bascode-2/music quantizer/solid-state dark room lighting/high-voltage regulator/anemometer/programmable power supply/Bascode-2 interface for the Junior Computer/electronic voltage regulator/battery eliminator/transistor selector/FSKleaner/useful tip/2N3055 super Darlington pair/EPROMmer using the Junior Computer

E8, December 1983

orbital - or telephone - operated flash light/ power controller for model railways/decoupling in digital circuits/LMU card/decimal-to-binary converter/movement detector/electronic two-tone metronome/pseudo Stereo/universal terminal/ultrasonic/infrared barrier/trick battery/power flasher

E9, January 1984

64-wait 2-dimensional bus board/MF/HF USB marine receiver/LED ornaments/symmetrical power supply/video amplifier/frost warning device/cisco phase/banking program/NOVIRAM: data storage without batteries bus extension/locomotive headlamp reverser applicator

E10, February 1984

gyrophone/how accurate is your watch?/digital cassette recorder/audio signal embellisher/universal active filter/ from thermometer to thermostat/ auto sleuth at work/wind direction indicator/Z80 EPROM programmer/home-made low-cost wiring probe/address decoding/appliator

E11, March 1984

6502 tracer/diesel tachometer/programmable disco light/video combiner/digitester with a difference/reversing buzzer/memory timing/mating logic families/capacitance meter/Bascode 2 for Junior plus VDU card/constant voltage source/CS ship select/video sync box/automatic battery charger

E 12, April 1984

petrol saver/triac control board/USF video and audio modulator/GET & GO/Eleby-rinth/varistor protection circuits/real-time analyzer (part 1)/sound generator/appliator

E 13, May 1984

optical memories/controlling the floppy disk drive motor/pulse generator/intelligent EPROM eraser/missing link/PC board pages/Z80 simulator/metronome extension/real-time analyser/variable time power supply/adial chip select/ tape contents detector the BF 494/signal injector

E 14, June 1984

none speak/short wave pocket radio/floppy tester/switching power supply/analytical video display/variometer/how many watts/transcendental lock of EXOR and EXNOR

gate/EPROM copier/digital cassette recorder/real-time analyzer (part 2)/RS 423 interface/analog frequency meter?

E 15, JULY 1984

selector, portable distress signal/ZX extension/disco drum/daisywheel typewriter printer interface/maximum and minimum memory/lead-acid battery charger/PSUs on PCs/merging BASIC programs/echo sounder/versatile audio peak meter.



E 16/17 AUG./SEPT 1984

Circuits special 84, more than 100 practical projects



E 18, OCTOBER 1984

selector/data communication by telephone/active cross over filter/digital cassette recorder with the ZX81/flash meter/digital tachometer/DIRPUT/SCART adapter/anodizing aluminium lamp saver/double-sided printed circuit boards/appliator/ telephone amplifier

E 19, November 1984

sinclair QL first impressions/dynamic RAM power supply/balancing transformers/video colour inverter/programming the 6845/ZX81/cassette pulse cleaner/direct-coupled modem/battery tester/RS 232 centronics converter?

dynamic pre-amplifier/h-i logic tester/how to recycle dry cell batteries/flashung badge

E 20, DECEMBER 1984

readership survey results/the story of valves/circuit boards and soldering/print user burglar deterrent/RS 232/V24: the signals/your TV receiver as a monitor/teletext valve amplifier/universal NiCad charger?

E 21, JANUARY 1985

the XR2206 in the function generator/short-hand BASIC/function generator/toroid switch/cumulative index 1984/with a pencil point/give your soldering tip a longer life/computer-controlled slide feeder/7 watt IC audio amplifier/toroidal transformers/microprocessor controller frequency meter (Part 2)/7400 Siren/light dimmer?

E 22, FEBRUARY 1985

tee leaves/selector/commodore cassette interface/VHF/UHF modulator/portable juicer amplifier/30 watt a.i. output stage/JBR swap/rumble detector/UP-controlled frequency meter/CMOS function generator/simple transistor tester/economical crystal time base/low voltage stabiliser/electrolytics run dry/appliator/CMOS ICs

E 23, MARCH 1985

electronics the easiest way/gyroflash/1.2 GHz input stage/microphone preamplifier/remote model control by microcomputer/DIY coprocessor/programmable rhythm box/EPROM selector/easy music/PLC meter/programmable keyboard encoder/appliator

E 24, APRIL 1985

KITT scanner/AXL amplifier pH meter/Speed for microcomputers/put out power nonogram/new keyboard for Spectrum/1a KHZ precision calibrator/variable counter/circuit/transistor unitiser/COS/MOS digital ICs/browsing and soldering/ultrasonic pressure meter/soldering aluminium



E 25, MAY 1985

Light powered radio/revolution circuit/revolver/light dry cell batteries/flashung badge



E 26, JUNE 1985

A/D and D/A conversion/programmable timer/Universal I/O bus/an IBM compatible micro/panoramax/digital/programmable array logic/L.C.D. thermometer/temperature-to-voltage converter/multi purpose time switch/reading-in-bed limiter/Selex-2/Selex-1/



E 27, JULY 1985

tone burst generator/infrared movement detector/an IBM compatible micro/RAM used as EPROM/service interval timer/electronic pantograph/digital oscillators/the short search/alphabetic display/solar battery/computer eye/Selex-3/

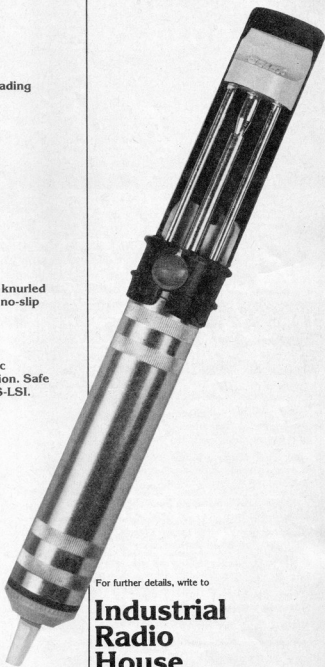
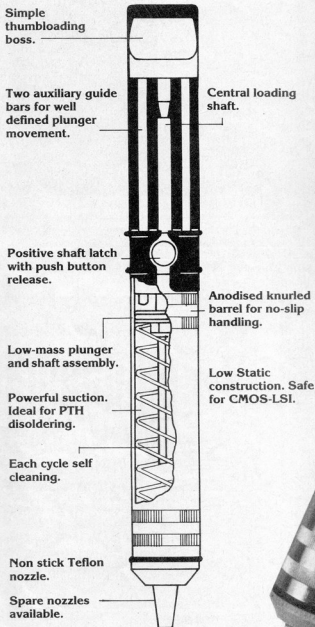
Back numbers of Elektor India currently available are detailed above, with a brief description of their contents :

- Price any one issue Rs. 7-50
- Aug/Sept issue Rs 15-00
- Price includes postage
- All payments in advance by M.O. or D.D. only. **NO CHEQUES, NO V.P.P. PLEASE**

• Send payment to : **Elektor Electronics Pvt. Ltd.** 52C, Proctor Road, Grand Road (E), Bombay-400 007, Phones : 367459, 369478.

Technical Perfection In Desoldering Art

SOLEX



For further details, write to

Industrial Radio House

Gandhi Bhavan, First Floor, Chunam Lane,
Off. Dr. Dadasaheb Bhadkamkar Marg,
Bombay 400 007, Phones: 382104.

SOLEX

India's largest selling
desoldering system, for
quick, easy and efficient
desoldering.

A New page has been added to LCR History !



VLCCR7

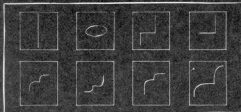
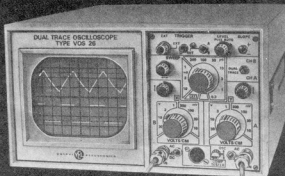
Measurement of **INDUCTANCE, CAPACITANCE, RESISTANCE** are greatly simplified by VLCCR 7. **No balancing, no adjustments.**

Connect the component to the terminals. VLCCR 7 gives you directly the digital reading of value and its loss factor simultaneously.

FOUR TERMINAL measurement eliminates inherent errors due to lead resistance. **GUARD TERMINAL** provided eliminates errors due to lead capacitance.

VLCCR 7 is the only instrument in India covering the widest ranges of **0.1 pf/uH/m ohm** (ie. **0.0001 ohm**) to **20,000 uf/200H/20 M ohm**.

*Do not be mad of B.W. if you do not need.
But a Scope with Component tester is all the while required.*



DIGITAL FREQUENCY COUNTER VDC 18



Smallest size ever made in INDIA

Battery cum mains operated
wide frequency range 30MHz
(our model VDC 19 is 500MHz)
Basic sensitivity of 10mv
Bright LED display 7 digit

VASAVI ELECTRONICS

(Marketing division) ph: 70995
630, Alkarim Trade Centre, Ranigunj
SECUNDERABAD-500 003. gms: VELSCOPE



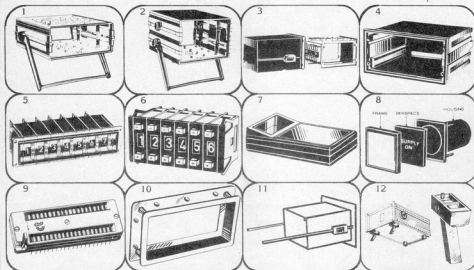
Range of our Products:

Oscilloscopes • Curve Tracers
Oscillators • Function Generators
Micro Processor Trainers

Digital

LCR Meters • Capacitance Meters
Multimeters • Milli OHM Meters
Micro Voltmeters • Frequency Counters

COMTECH



1. Instrument Case T-220 For Digital Table Top Test Instrument
2. Instrument Case T-220 H H = 145 MM. For Analog Instruments.
3. DIN STD Instrument Case + Cassette 96 x 96 x 150
4. Instrument Case 96 x 48 x 90 1/2 DIN STD
5. Thumb Wheel Switch T-21
6. Coded Push Button Switch T-24 T-24 W = 7.6 mm
7. Hand Held Instrument Case T-29 29 x 81 x 145
8. Annunciator Kit T-54 54 x 54 mm
9. Zero Insertion Force 40 Pin DIL IC Socket
10. Bezel For 3 1/2 Digit
11. Instrument Clamp-IC-200
12. Instrument Rest Kit T-13

For more information, contact:

COMPONENT TECHNIQUE

8, Orion, L.P. Road, Andheri (W), Bombay-400 058. Tel: 4224066

YOUR DEPENDABLE SOURCE...

<p>ECC ELECTRONICS CORPORATION OF INDIA LIMITED</p> <p>DIAMING SILICON DIODES POWER TRANSISTORS, ETC</p>	<p>MELTRON</p> <p>SEMICONDUCTOR PRODUCTS</p>	<p>KELTRON</p> <p>ELECTROLYTIC CAPACITORS</p>
<p>ITI MANUFACTURING INDUSTRIES LTD.</p> <p>METALLIZED POLYESTERS POLYCARBONATE CAPACITORS COMPARISON CAPACITORS</p>	<p>PROTECTION (INDIA)</p> <p>DEFICACY APPROVED GLASS CAPACITORS FAST ACTING & TIME DELAY FUSES, INSULATING COMPONENTS LED LAMP HOUSINGS AND CONNECTORS ETC.</p>	<p>COMPONENT TECHNIQUE INDIA PVT. LTD.</p> <p>TERMINAL SWITCHES AND DRIVING INSTRUMENT CASES</p>
<p>PARAMOUNT INDUSTRIES</p> <p>ELECTROSTATIC RELAYS 5 & 10 AMP ENCLOSED TYPE 50 20 AMP POWER RELAY 173, 1700</p>	<p>4 ELECTRONICS</p> <p>ELECTROLYTIC CAPACITORS</p>	<p>EP ELECTRONIC PRODUCTS</p> <p>TERMINAL BLOCKS, FUSE HOUSING LAMP HOLDERS, CONNECTORS, WIRE PRODUCTS</p>
<p>MEDIA ENGINEERING ENTERPRISES</p> <p>PROFESSIONAL GRADE PUSH BUTTON SWITCH</p>	<p>HINDLEVIAN CONNECTORS (P) LTD.</p> <p>TRANSISTORS, SMT, PRT, IC, LED'S ETC.</p>	<p>Afcroset AFCC LTD</p> <p>HEAT SINKS, MOUNTING ACCESSORIES ETC.</p>

TEXONIC INSTRUMENTS

5 A/SHAFIAT STREET,
MOUNT ROAD,
MADRAS-605 002
Ph: 44445/44412

2, MANOVBAPPA LANE,
S.J.P. ROAD CROSS,
BANGALORE-560 002
Ph: 224430/224429

Our Most Important Component - SERVICE

**WE KEEP LARGEST STOCK
AT
THE MOST CHEAPEST PRICE**

<p>EPROM</p> <p>● 2716 ● 2732 ● 2532 ● 2764</p>	<p>REGULATOR</p> <p>● 7805 ● 7809 ● 7812 ● 7815</p>	<p>CERAMIC FILTER</p> <p>SFE 5, 5 MB SFE 10, 7 MB</p>
<p>TTL/CMOS</p> <p>74 LS00-373 4001-45106</p>	<p>SCR/TRIAC</p> <p>6A-40A 400V-600V</p>	<p>OP-AMP</p> <p>● 324 ● 339 ● 741 ● 158 ● 258 ● 358</p>
<p>TBA-SERIES</p> <p>● 800 ● 810 ● 820 ● 920</p>	<p>TDA-SERIES</p> <p>● 1154 ● 1170 ● 1190 ● 2593</p>	<p>TRANSISTORS</p> <p>● 2N ● BL ● BD ● BF-SERIES</p>

MANY MORE SALEABLE ITEMS

CONTACT:



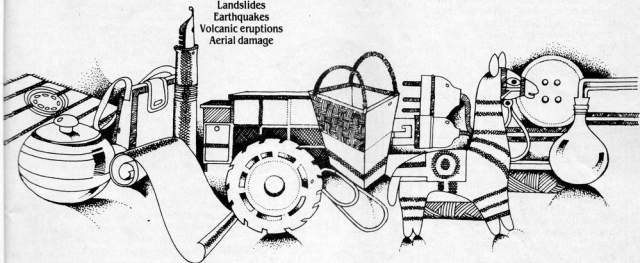
**梧槽电子企业
ROCHOR ELECTRONICS ENTERPRISE**

500B, BLK. 1, ROCHOR ROAD, (ROCHOR CENTRE) SINGAPORE 0718.
TEL: 2941094, 2928364 TELEX: RS 26483 ROTRON CABLE: ROTRONIC

Here are 13 reasons why every small scale industry should take the new Fire Insurance Policy

Risks like:

- Fire
- Lightning
- Riots
- Strikes
- Malicious damage
- Explosions
- Floods
- Storms
- Cyclones
- Landslides
- Earthquakes
- Volcanic eruptions
- Aerial damage



Here is one weighty reason why even
the tiniest industry can afford it:

**Premiums considerably reduced:
you pay as little as One rupee for a
Thousand insured.**



आपत्काले रक्षिष्यामि

GENERAL INSURANCE CORPORATION OF INDIA

This policy is specially for small scale industries whose original investment
does not exceed Rs.5 lacs and where total sum insured is not over Rs.10 lacs.



National Insurance
Company Limited.



The New India
Assurance
Company Limited.



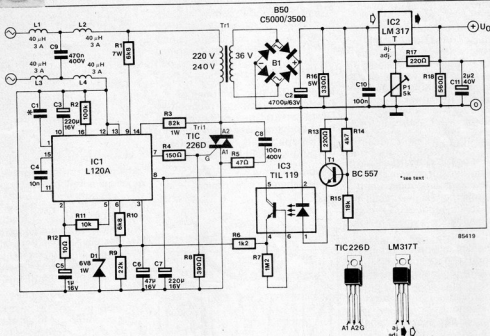
The Oriental
Insurance
Company Limited.



United India
Insurance
Company Limited.



mains power supply with primary regulation



The unusual circuit shown in figure 1 has an unusual efficiency: according to SGS, this amounts to no less than 37 per cent at an output voltage of 3 V and output current of 2 A. With traditional secondary regulation, an efficiency of about 8 per cent would have been normal. The output voltage can be varied over the range 1.2...25 V, and the output current can be 1.5 A at any of these voltages, provided IC₂ is mounted on a suitable heat sink.

Another advantage of primary regulation is that the power supply is protected against variations in the mains supply. This aspect is normally

ignored with secondary regulation, as it is assumed that primary fluctuations have no effect on the secondary regulation. The present circuit is, therefore, of particular importance for use where the mains supply is subject to large variations.

The regulation functions so that the voltage drop across voltage regulator IC₂ is held constant. This voltage drop is transferred by current source T₁ into a current through the LED in the opto-coupler. When the voltage drop diminishes, the current through the LED is smaller. The transistor in the opto-coupler gets less drive, and the voltage at pin 3 of IC₁ drops.

Voltage regulator IC₁ contains a complete circuit for phase gating control with silicon-controlled rectifier T₁. The gating angle of this triac depends on the comparison between the direct voltage at pin 3 and an on-chip generated sawtooth signal, the frequency of which is determined by capacitor C₁ (= 100 n). In our example, the triac switches the mains voltage earlier so that buffer capacitor C₂ receives more energy. Noise caused by the phase gating circuit must be prevented of entering the mains supply by a mains noise filter as shown.

SGS application



battery fitness centre

Tomezzoli

This circuit is designed primarily for maintaining lead-acid batteries that are often not used for long periods in good working order. It charges the battery, after which the battery discharges slowly through its internal resistance and the present circuit. When the state of charge reaches a predetermined level, the charger is switched on again, the battery charges, and so the cycle repeats itself.

The circuit is based on Schmitt trigger T₁/T₂. Zener diode D₃ determines the state of charge at which the charger is switched off. Resistor R₂ provides the required hysteresis. With the mains disconnected and no battery connected to the battery terminals, check with voltages (from a regulated power supply) of 13.6 V and 12.5 V applied across the battery terminals that the relay switches off and on respectively. The "on" threshold may be corrected

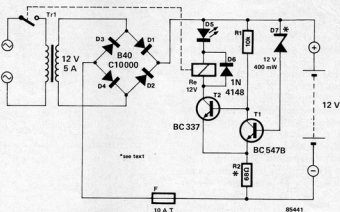
by, for instance, connecting a 1N4148 (cathode to +line!) in series with D₇. The "off" threshold is corrected by altering the value of R₂, for example, by replacing this component with a 100 Ω preset.

It is, of course, possible to replace the mains transformer and bridge rectifier by a battery charger (see, for instance, *Elektron*, July 1984, p. 7-39), in which case the rest of the circuit can be fitted inside the charger.

It is not possible to connect a full discharged battery to the circuit, because the relay would not be energized. Such a battery should first be charged to above 10 V, but it is also possible to fit a switch in parallel with the relay contact and switch on the mains with that.

It is possible, of course, to maintain two 12 V batteries in condition by doubling the secondary voltage of the mains transformer, the zener voltage of D_7 , the hysteresis, the rated coil voltage, and connecting the batteries in series across the terminals.

Fuse F_1 is necessary to provide protection against short circuits. The transformer primary circuit may also be protected by a fuse (like F_1 , a delayed action type) rated at 1 A.



The circuit does not need a smoothing capacitor because that function is carried out by the battery.

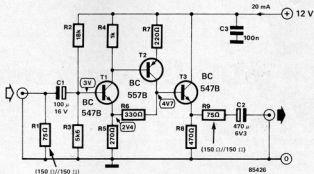


video buffer/repeater

This universal video amplifier is intended as a buffer/repeater in a long coaxial cable to keep the signal at a reasonable level. Its gain is about 6 dB. The circuit is built from readily available components: some transistors and a few others.

The circuit consists of a two-stage amplifier, T_1 and T_2 , and an emitter follower that functions as impedance converter. The bandwidth at -3 dB is not less than 20 MHz. Current consumption at a supply voltage of 12 V amounts to about 20 mA. The power supply needs to be regulated to prevent lines and other noise on the screen.

The buffer/repeater is very suitable for



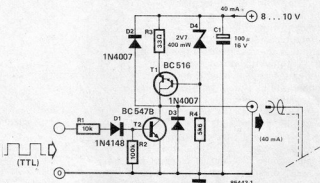
being combined with the video selector featured elsewhere in this issue. The present circuit, with R_1 omitted,

is then used as a buffer for the output of the inverter. Its input impedance is then around 4 k Ω .



serial line driver and receiver

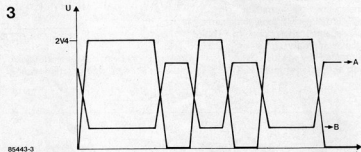
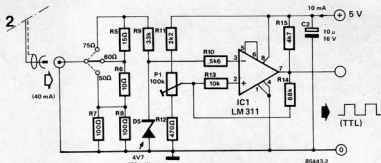
This circuit owes its existence to the need for data communication over relatively long distances (up to 100 metres), inexpensively, reliably, and suitable for speeds up to 2400 bauds. At the distances considered, the main expense is normally the cable, so here a readily available 60 Ω coaxial cable is used. Because of its relative immunity to noise, current drive is employed. In the line driver — figure 1 — transistor T_1 , diode D_1 , and resistors R_1 and R_2 form a current source that can be fed direct from a non-regulated supply of 8...10 V. The transistor should be mounted on a heat sink. The current level of 40 mA ensures an adequate



input signal to the line receiver. Transistor T_2 is a current switch that short-circuits the current source and the cable to earth of the input to the driver is logic high: only when that input is logic low, is the current of 40 mA fed into the cable. Diodes D_2 and D_3 protect the driver against noise emanating from the cable, while capacitor C_1 decouples the supply line.

The line receiver is based on a type LM 311 comparator. Matching of the input is effected by a wire link at a relevant tap of resistive divider $R_5-R_6-R_7/R_8$ (in our case: 60 Ω). Resistors R_9 and R_{10} , and diode D_5 protect the LM 311 against noise emanating from the cable. The sensitivity of the receiver is set with P_1 . Resistor R_{14} provides some hysteresis. Pull-up resistor R_{15} ensures that IC₁ provides at its pin 7 a TTL output signal that is in phase with the input signal to the line driver.

The circuit is best calibrated with the aid of an oscilloscope once it has been installed in its final position. The level of input to the receiver is then compared with the voltage at the wiper of



P₁. The setting of P₁ is optimum when the voltage at its wiper (wave form A in figure 3) is exactly opposing the input voltage (wave form B in figure 3).



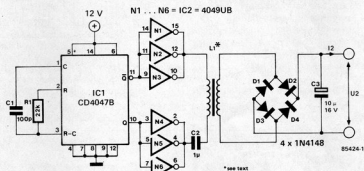
DC/DC converter

W. Jitschin

In circuits where two signal paths must be electrically isolated, use is often made of an opto-coupler. Unfortunately, these devices require two power supplies: one for the sender, and the other for the receiver. In industrial and professional undertakings this requirement is met by a proprietary DC/DC converter. As these are by and large very expensive, they are not of very much interest to the average hobbyist. However, the do-it-yourself converter presented here is much less expensive and, moreover, easy to build.

The circuit diagram in figure 1 shows that the converter consists of an oscillator, IC₁, and a driver, IC₂, on the primary side, and of a rectifier, D₁...D₄, and buffer capacitor, C₃, at the secondary.

In our prototype, operating from a 12 V battery at the maximum 74 per cent efficiency, we measured a secondary output voltage of 10.64 V, and a secondary output current of 9 mA (the corresponding primary current amounted to 10.8 mA). The secondary current should not exceed 10 mA, because the secondary output voltage then drops below 10 V and the efficiency deteriorates. That applies also to low-load conditions: when the secondary is open-circuit, the output voltage is 14 V, but the efficiency is, of



course, 0 per cent! In other words: the circuit works optimally at a secondary load current of 9 mA.

Oscillator IC₁ operates at a frequency of around 100 kHz. Its two output signals are each amplified in three parallel-connected buffers contained in IC₂, and then applied to the

primary of the isolating transformer. The voltage induced in the secondary winding is rectified and smoothed by C₃. The stated value of that capacitor is more than adequate for the relatively high secondary frequency of 200 kHz.

The isolating transformer is a DIY item: it is wound on a pot core of 22 mm dia. and 13 mm high with 0.35 mm dia. enamelled copper wire — 80 turns for the primary and 80 turns for the secondary. The specific inductance, A_L, of the core should be 400 nH. The core should not have an air gap. Insulating foil should be placed between the two windings to ensure an isolating voltage of 4 kV.

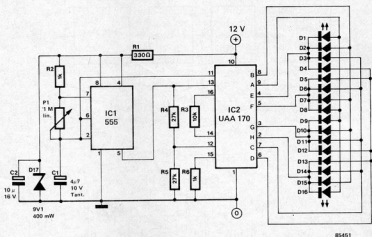


miniature running lights

J P Truong

The type UAA170 integrated circuit is normally used to drive up to sixteen LEDs, and the present circuit is no exception, as can be seen from figure 1. The 555 is used as an astable multivibrator, but note that its output is not connected to the UAA170. Instead, the driver is fed from the junction of an RC network with a triangular voltage, the period of which is set with P_1 . It is advisable to use a tantalum capacitor in the C_1 position to keep the leakage current down.

The voltage at the input of IC_2 must not exceed 6 V. To ensure that the triangular voltage remains below that value, the supply voltage of IC_1 is limited to 9.1 V by D_{17} . If necessary, this zener diode may be replaced by an 8.2 V or even 6.8 V type. The voltages on pins 12 and 13 determine the voltage range swept by the LEDs. The reference voltage for D_{16} is provided via pin 5 of IC_1 , and amounts to about $\frac{2}{5}$ of the supply voltage to the 555. The reference voltage for D_1 is



determined by the potential at the junction of R_2 - R_6 (=pin 12 of IC_2), which with values shown amounts to about 3 V.

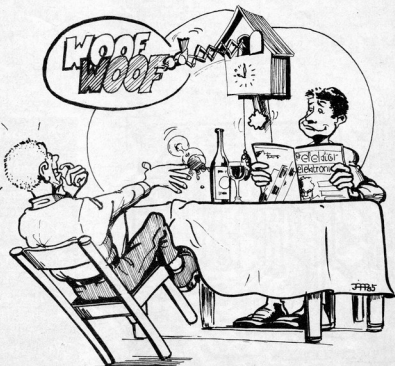
Current consumption is around 30 mA, so that battery supply is only possible with two PP3s in series and a 12 V regulator.



electronic dog

To produce a faithful reproduction of the voice of man's best friend, we have borrowed several ideas from our music synthesizer. When push button switch S_2 is pressed, the frequency of voltage-controlled oscillator (VCO) A_1 - A_2 changes in about an eighth of a second from almost 0 Hz to a presettable value of 100...1000 Hz. That signal is passed through band-pass filter A_3 - A_6 , the centre frequency of which corresponds with the highest VCO frequency. Voltage-controlled amplifier (VCA) T_1 ensures that the single pulse generated by the VCO when S_2 is open cannot be heard. Gates N_1 and N_2 form a monostable relaxation oscillator. When S_2 is closed, a short pulse appears at the output of N_2 that charges capacitor C_2 . Because of R_3 , the pulse shape will be as shown in figure 1. This pulse controls the output frequency of the VCO as also shown in figure 1. Potentiometer P_1 determines the highest frequency: its setting depends on whether you want the sound of a yapping poodle or the deep bark of an alsatian.

The function of C_2 is similar to that of C_2 : it shapes the pulse applied to the VCA. This transistor behaves as an





microphone amplifier with mute switch

Microphones, unfortunately, produce only a small signal and they, therefore, require a special pre-amplifier to boost their output. Because small signals are involved, the signal-to-noise ratio of the pre-amplifier is a very important parameter.

In this article, we present two circuits for a pre-amplifier suitable for virtually all occasions: a symmetrical and an

asymmetrical version. We have incorporated a mute switch, which speakers can use when they want to clear their throat. As there is an number of low-noise operational amplifiers available nowadays, the cost of these pre-amplifiers is relatively low.

The asymmetrical version is shown in figure 1. Switching between high and

low impedance matching is possible with switch S_2 . Opamp A_1 is arranged as an AC amplifier with a gain of around 27 dB. This stage may also be used as a DC amplifier: R_3 and C_1 are then omitted, and the value of R_2 is lowered to 22 k. Capacitor C_2 limits the bandwidth of the amplifier to ensure stable operation. Irrespective of whether A_1 functions

1

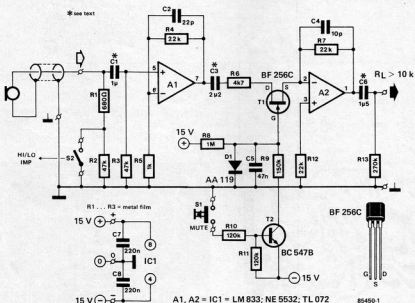


Figure 1. Circuit of the pre-amplifier with asymmetrical input.

2

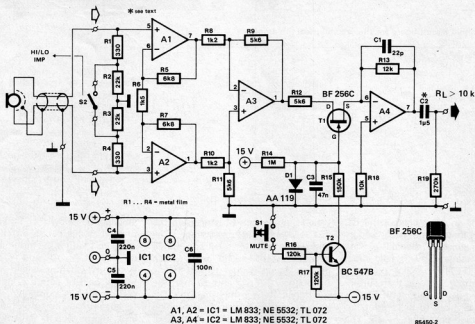


Figure 2. Circuit of the pre-amplifier with symmetrical input.

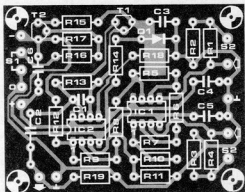
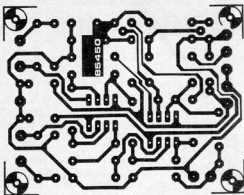


Figure 3. Printed circuit board for the asymmetrical pre-amplifier.

Parts list (figure 3)

Resistors:

- R₁ = 680 Ω metal film
- R₂, R₃ = 47 k metal film
- R₄, R₇, R₁₂ = 22 k
- R₅ = 1 k
- R₆ = 4k7
- R₈ = 1 M
- R₉ = 150 k
- R₁₀, R₁₁ = 120 k
- R₁₃ = 270 k

Capacitors:

- C₁ = 1 μ/16 V MKT (see text)
- C₂ = 22 p
- C₃ = 2μ2 MKT (see text)
- C₄ = 10 p
- C₅ = 47 n
- C₆ = 1μ5 MKT (see text)
- C₇, C₈ = 220 n

Semiconductors:

- D₁ = AA119
- T₁ = BF256C
- T₂ = BC547B
- IC₁ = LM883; NE5532; TL072

Miscellaneous:

- S₁ = spring-loaded push to make switch
- S₂ = miniature SPST switch
- PCB 85450-2

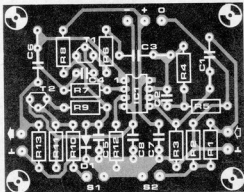
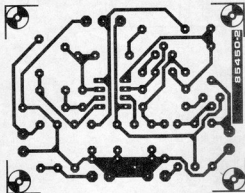


Figure 4. Printed circuit board for the symmetrical pre-amplifier.

Parts list (figure 4)

Resistors:

- R₁, R₄ = 330 Ω metal film
- R₂, R₃ = 22 k metal film
- R₅, R₇ = 6k8
- R₆ = 1k5
- R₈, R₁₀ = 1k2
- R₉, R₁₁, R₁₂ = 5k6
- R₁₃ = 12 k
- R₁₄ = 1 M
- R₁₅ = 150 k
- R₁₆, R₁₇ = 120 k
- R₁₈ = 10 k
- R₁₉ = 270 k

Capacitors:

- C₁ = 22 p
- C₂ = 1μ5 MKT*
- C₃ = 47 n
- C₄, C₅ = 220 n
- C₆ = 100 n

Semiconductors:

- D₁ = AA119
- T₁ = BF256C
- T₂ = BC547B
- IC₁, IC₂ = LM833; NE5532; TL072

Miscellaneous:

- S₁ = spring-loaded push to make switch
- S₂ = miniature SPST switch
- PCB 85450-1

*MKT = metal-plated plastic polytheterealtale foil

For Components, Sources See Page 9-38

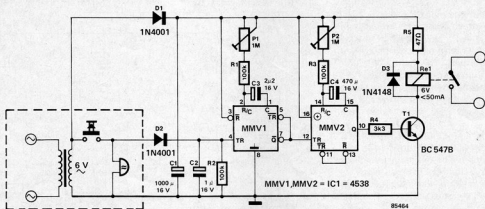
as a DC or an AC amplifier, the DC component in its output is blocked by C₃. The amplified AC signal is applied to muting stage T₁. This field-effect transistor (FET) normally conducts and the output of A₁ is then further amplified in A₂ by about 5. Finally, the signal is taken to the output terminal via high-pass filter R₁₃-C₆. The load must be greater than 10 kΩ.

When mute switch S₁ is pressed, the FET receives a negative voltage at its gate and is switched off. Capacitor C₅ determines the speed with which muting occurs within certain limits. Capacitors C₁, C₃, and C₆ may be electrolytic types: measure the DC level at both terminals to determine which way they should be connected! The symmetrical version of the pre-

amplifier is shown in figure 2. The only difference between this and that in figure 1 is that the input stage now consists of A₁, A₂, and A₃ to obtain symmetry. Opamps A₁ and A₂ provide a total gain of about 20 dB. Opamp A₃ functions as a differential amplifier to ensure that common-mode noise and interference is effectively suppressed.



burglar deterrent



Most burglar deterrent systems are based on the same principle: once the presence of an unwanted or suspicious individual has been detected (by electronic or other means), some action ensues which makes it clear to passers-by or neighbours that something is amiss. It is often overlooked that the unwanted visitor first had to ascertain that there is nobody at home. The majority of burglars who operate by daylight just ring the bell. Once they have repeatedly rung without anyone answering the door, they go about

their nefarious ways. Once inside, they may well set off a conventional alarm, but by then it is already too late. The circuit proposed here was designed to prevent the intruder getting that far. When the bell is rung, a number of monostables is actuated, which, after a suitable delay, switches on a cassette player that generates an awesome sound. This can vary from the barking of a large dog to the roar of a lion, depending on the premises. Sometimes a simple "sorry, no canvassers" may be adequate. The circuit consists basically of two

monostables. The delay between the ringing of the bell and the cassette player being switched on is preset with P_1 between 0.22 and 2.4 seconds. The time the cassette player operates is set with P_2 between 47 s and 8 m 37 s. The cassette player is switched on via the relay contacts. The circuit is powered by the bell transformer. In the circuit it is assumed that this is a 6 V type, and the relay is, therefore, also a 6 V type (which here draws a current of 50 mA).



siren

In spite of its modest configuration, the circuit shown here is capable of generating quite a sound. This is made possible by the n-channel MOSFET, T_1 , which drives the loudspeaker.

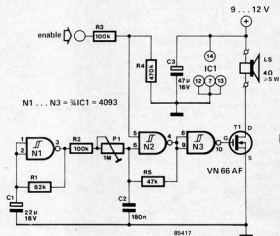
Such a MOSFET can be driven direct by CMOS logic circuits, and the type chosen here has an output (=drain-source) resistance of only three ohms. Moreover, its drain current can be as high as 1.7 A, while the maximum drain-source voltage is 40 V. These parameters are independent of the polarity of the applied voltage, since the device has internal diode protection.

Since the MOSFET is virtually indestructible, it is perfectly all right to load it with just a loudspeaker.

The circuit can be controlled simply from a computer, and is operated by making the ENABLE input logic high (which can also be done with a simple

switch instead of a computer). When the input at pin 5 of gate N_2 is high, the pulses from Schmitt trigger N_1 cause N_2 to oscillate. The output of N_2 is applied to the MOSFET via

buffer N_3 . The frequency of N_2 can be adjusted with P_1 . As to applications, this siren is particularly suitable for use in alarm installations.





metal pipe detector

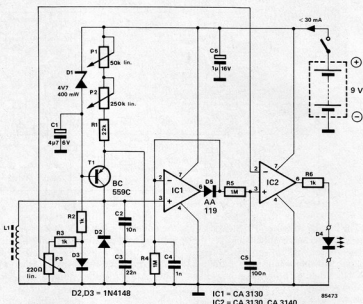
Water and gas pipes, as well as electrical conduit, embedded in walls are not easy to trace, although this is essential when work is to be carried out to the wall. This handy little unit will be a godsend at such times.

The principle of the detector is based on the property of metals of absorbing magnetic energy when they are brought into a magnetic field.

Transistor T_1 in figure 1 is a simple LC oscillator, of which the sensor, L_1 , forms a part. The oscillator frequency is around 15 kHz. When energy is withdrawn from the magnetic field around L_1 by a metal object, the alternating voltage across the LC circuit will diminish. By rectifying that voltage in IC₁, and applying the resultant direct voltage to a differential amplifier, IC₂, which compares it with a voltage preset with P_2 , an on/off indication is obtained. When L_1 is brought in the vicinity of metal, D_4 goes out. The sensitivity of the detector is set with P_1 and P_3 .

The unit is powered by a 9 V battery (PP3).

To calibrate the detector, adjust P_1 for maximum resistance and connect an oscilloscope to the collector of T_1 . Adjust the peak value of the oscillator signal with P_2 so that the oscillator just does not stop working. This is checked by adjusting P_3 so that the



L_1 = 500 turns enamelled copper wire,
 $\phi 2 \dots \phi 3$ mm dia;
on ferrite rod 250 mm long and 10 mm dia.

LED just lights. If then a coin is held near the ferrite rod, the LED should go out, indicating that the oscillator has ceased working.

At the start of the search, use the smallest peak value of the oscillator signal (P_1 at maximum resistance),

combined with the lowest trigger level (wiper of P_3 to earth). After the location of the pipes has been ascertained roughly, the peak value of the oscillator signal and the trigger level can be increased until the required accuracy is obtained.

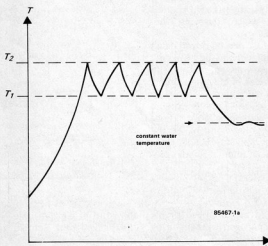


CH boiler control

If you still alter your central heating system's boiler thermostat according to the season (many people nowadays leave it at the same — fairly high — setting throughout the year), this may cause the boiler to be switched on and off too frequently when the weather is unseasonably cold (see figure 1a). This problem may be resolved by the present circuit which prevents the boiler being switched on for some time, t_d , after the switch-off temperature, T_2 , has been reached. After t_d has lapsed, the boiler temperature, T , should have dropped well below the switch-on temperature, T_1 (see figure 1b).

The circuit in figure 2 is an extension of the central heating monitor (*Elektron*, August/September 1984, p. 8-24). The make contacts of a relay

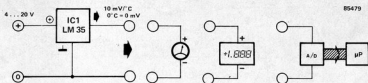
1a



sors to measure in degrees Celsius requires a very stable reference voltage that must be deducted from the reading.

Another advantage of the LM35 is its very low current consumption of less than 60 μ A. This means a long battery life and small internal power dissipation, so that errors caused by internal heat are minimal: 0.1 $^{\circ}$ C with a battery voltage of 4 V.

The sensor can be connected direct to an analogue or digital multimeter, or, more interestingly, to a computer which can then process and store the information. A suitable interface for this purpose is described in *direct reading digitizer* elsewhere in this issue.



The accuracy of the LM35/LM35C is typically 0.4 $^{\circ}$ C at 25 $^{\circ}$ C.

To keep the self-heat minimal, the load should be not smaller than 5 k Ω . If a long screened cable is used between the sensor and indicator, an RC network (10 Ω in series with 1 μ F) should be connected between the output of the sensor and earth to prevent any oscillations.



12-volt NiCd battery charger

K Williams

If you attempt to charge a 12 V NiCd battery from a 12 V lead-acid car battery, you will soon find that that is not really possible: the charging voltage should be somewhat higher than the nominal battery voltage. A 12 V battery should be charged from a source of about 14 V.

The present circuit is, therefore, a voltage doubler based on the well-known 555 IC. The IC oscillates, which means that output 3 is connected alternately with earth and the +12 V supply voltage.

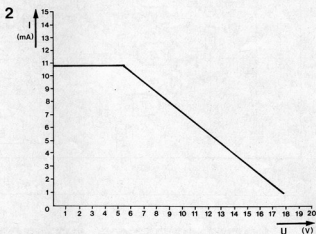
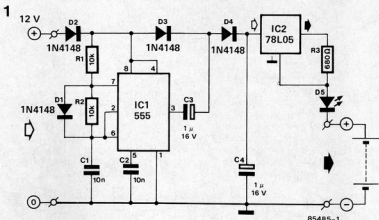
When pin 3 is logic low, C_3 is charged via D_2 and D_3 to almost 12 V. When pin 3 is logic high, the voltage at the junction of C_3 and D_3 becomes almost 24 V, because the negative terminal of C_3 is at +12 V and the capacitor itself is charged to about 12 V. Diode D_2 is then reverse biased, but D_4 conducts, so that C_4 is charged to just over 20 V, which is ample for our purposes.

The 78L05 in the IC₂ position functions as a current source, which tends to keep its output voltage, U_o , appearing across R_3 , at 5 V. The output current, I_o , is therefore easily calculated from

$$I_o = U_o / R_3 = 5 / 680 = 7.4 \text{ mA.}$$

The 78L05 itself also draws current: the central terminal (normally earthed) delivers about 3 mA. The total load current is, therefore, of the order of 10 mA, which is a good value for continuous charging NiCd batteries. The LED has been incorporated to indicate that charging current flows.

The characteristic of the charging current versus battery voltage in figure 2 shows that the circuit is not perfect: a 12 V battery will be charged with a current of only about 5 mA. There are several causes for this:



- the output voltage of the circuit tends to drop with increasing current;
 - the voltage drop across the 78L05 is about 5 V to which must be added the 2.5 V the IC needs to operate correctly;
 - there is a voltage drop of about 1.5 V across the LED.
- None the less, a 12 V NiCd battery with a rated capacity of 500 mAh can be charged continuously with a current of 5 mA, which is 1 per cent of its capacity.

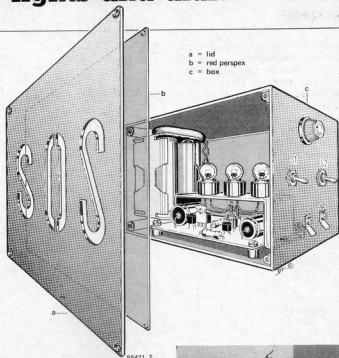
bicycle lights and alarm

A bicycle or tricycle should, as everyone knows, be fitted with front and rear lights. The noteworthy aspect of the lights circuit described here is that it also provides a visible alarm, which is primarily intended for invalid road users. When such handicapped people are in need of assistance during the day, this is quickly spotted by passers-by. At night, this is, unfortunately, not so, whence the present circuit.

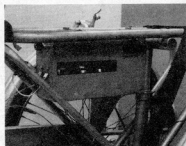
The usual dynamo or battery is replaced by a 6 V rechargeable lead-acid battery, which ensures that the bicycle lights are operational even when the bicycle is not moving. When the rider is in need of assistance, the alarm can be switched on: in addition to the normal lights, a small display with the word "HELP" will then flash. Such a signal for help is not easily overlooked!

The circuit is based on an astable multivibrator, which does not operate when alarm switch S_2 is open. Pro-

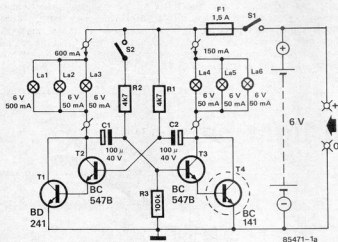
2



a = lid
b = red perspex
c = box



1a



85471-1a

vided S_1 is closed, the front and rear lights are on, however.

When the alarm switch, S_2 , is closed, the multivibrator operates, which causes the normal lights and the HELP lights to flash alternately.

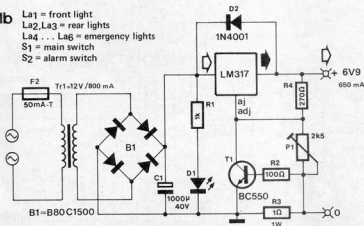
The circuit is powered by a 6 V 1.8 Ah lead-acid battery which, when properly charged, is sufficient to keep the lights on for about three hours.

The circuit can be fitted in a small, preferably water-proof, case. Lamps $La_2 \dots La_6$ light the letters "HELP" that have been cut out in the lid. The BC141 should be fitted onto a small heat sink.

Because of the need of regularly charging the battery, the case should be fitted to the vehicle in a manner which allows easy removal and attachment. A circuit for a suitable charger is given in figure 1b. This provides a constant charging voltage of 6.9 V (preset with P_1), while the charging current is limited to about 650 mA. This enables the battery to be fully charged in around 3 hours. The charging voltage should be set carefully, otherwise the battery will not be charged correctly.

1b

- La₁ = front light
- La₂, La₃ = rear lights
- La₄ ... La₆ = emergency lights
- S₁ = main switch
- S₂ = alarm switch



85471-1b

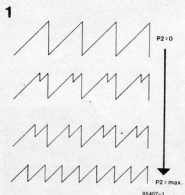


melodic sawtooth

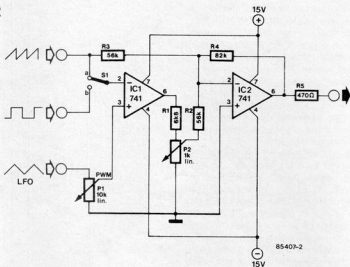
H Millian

Even in this era of programmable, polyphonic synthesizers, interest in simple, monophonic keyboard instruments remains. Many FORMANT owners are still proud of their, probably first, home-built synthesizer and are still on the look-out for new circuits for the generation of exotic sounds. For all those, here is an easy-to-build circuit that can convert a sawtooth signal at its input into an output of double the frequency and half the peak value of the input signal (figure 1).

Comparator IC₁ transforms the sawtooth signal into a rectangular



2



signal (see figure 2). Adder IC₂ combines the original input signal and the rectangular signal.

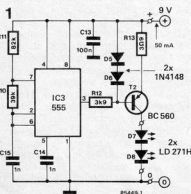
An additional LFO (low frequency oscillator) connected as shown provides pulse-width modulation of the rectangular signal, which has a greatly beneficial effect on the output signal. When switch S₁ is set to position b, it is possible to inject a rectangular

signal whose frequency is independent of the sawtooth frequency, which greatly increases the number of melodic variations, as anyone acquainted with synthesizers knows. Power requirements can be met direct by the FORMANT or any other ± 15 V symmetrical supply. Current consumption is not higher than 10 mA.

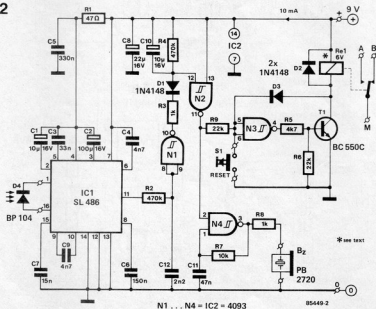


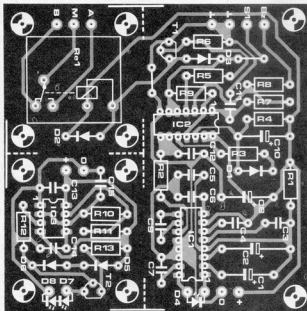
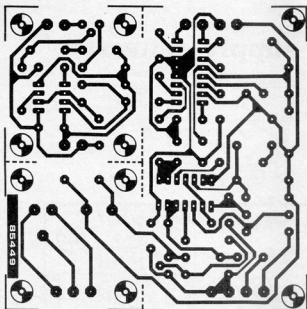
infra-red light barrier

Infra-red light barriers enjoy great popularity as timing devices at sports venues, as detectors in alarm installations, as optoelectronic switches in counting equipment, and many others, because of their low cost and immunity to electrical interference. The present light barrier consists of a transmitter and a receiver.



2





The transmitter, shown in figure 1, consists of an astable multivibrator (AMV), IC₃. The output of the AMV, pin 3, consists of a pulse stream with a duty factor of about 30 per cent. The output is connected to a constant-current source, T₂. This source provides infra-red transmit diodes D₇ and D₈ with a current of just over 20 mA, which pulsates in rhythm with the output signal of the AMV. The infra-red light is, therefore, transmitted in rhythm with the pulse stream also.

The receiver, shown in figure 2, is based on an SL486 demodulator, IC₁. The output of the demodulator, pin 11, also consists of a 10 kHz pulse train with a duty factor of around 30 per cent. This pulse stream is applied to integrator R₂-C₁₂. The logic level at the input of N₁ remains low as long as D₄ receives the pulsating infra-red

light. Because of this, monostable N₂ is disabled, and oscillator N₄, which drives a piezoelectric buzzer, is switched off. Relay Re₁ is, however, energized via N₄ and transistor T₁. When the pulse stream between D₇-D₈ and D₄ is broken, the logic level at pin 11 of IC₁ goes high, so that the output of N₁ becomes logic 0, which triggers monostable N₂ via D₁. Oscillator N₄ is then switched on and actuates the buzzer. At the same time, N₃ ensures that T₁ is switched off, so that the relay returns to its quiescent state.

When the monostable pulse decays, which with the stated values of R₂ and C₁₀ is after about 5 seconds, oscillator N₄ stops and the alarm tone ceases. Diode D₃ ensures that the relay remains in its rest state, however, by transferring the high voltage level of the collector of T₁ to the input of

Parts list (receiver)

Resistors:

R₁ = 47 Ω
R₂, R₄ = 470 k
R₃, R₈ = 1 k
R₅ = 4k7
R₆, R₉ = 22 k
R₇ = 10 k

Capacitors:

C₁, C₁₀ = 10 μ/16 V
C₂ = 100 μ/16 V
C₃ = 33 n
C₄, C₉ = 4n7
C₅ = 330 n
C₆ = 150 n
C₇ = 15 n
C₈ = 22 μ/16 V
C₁₁ = 47 n
C₁₂ = 2n2

Semiconductors:

D₁...D₃ = 1N4148
D₄ = BP104
T₁ = BC550C
IC₁ = SL486 (Plessey)
IC₂ = 4093

Miscellaneous:

Re₁ = PCB type relay, 6 V
Bz = piezoelectric buzzer
(Toko type PB2720 or equivalent)
S₁ = spring-loaded push-to-make switch

Parts list (transmitter)

Resistors:

R₁₀ = 39 k
R₁₁ = 82 k
R₁₂ = 3k9
R₁₃ = 3k9

Capacitors:

C₁₃ = 100 n
C₁₄, C₁₅ = 1 n

Semiconductors:

D₅, D₆ = 1N4148
D₇, D₈ = LD271H
T₁ = BC560
IC₁ = 555

Miscellaneous:

Reflectors for D₇ and D₈ (optional)
PCB 85449

For Components Sources See Page 9-38

N₃ whose consequent low logic output continues to hold the transistor off.

The equipment switched by the relay contacts, therefore, does not only indicate when the light barrier has been interrupted, but also when the supply voltage has failed. The relay is re-energized when reset switch S₁ is operated. If D₃ and S₁ are omitted, the relay is re-energized when the monostable pulse has decayed.

Current consumption of the transmitter is about 50 mA; that of the receiver around 10 mA.

The printed circuit board shown in figure 3 is intended to be cut into three along the dashed lines, although it may not be necessary in some situations to cut the relay section from the receiver section. If the latter two are separated, they should on completion be interconnected by a suitable cable.



negative supply converter

It is sometimes required in certain circuits that are powered from just one battery to derive a negative supply voltage from the positive battery potential. As the loading of such negative lines is normally pretty minimal, it is possible to use a TL 497A IC to provide the negative voltage. This saves a transformer, rectifier, and a smoothing capacitor.

The TL 497A is a switch-mode IC from Texas Instruments, that may be used as an upwards/downwards transformer, but also as a negative supply converter.

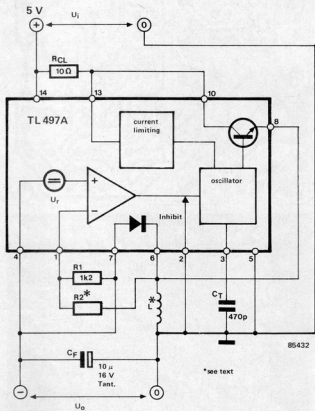
Inductor L makes it all possible, because when the on-chip transistor is switched off, a fairly large back-e.m.f. is generated across L , which causes a negative potential at the emitter of the transistor. The diode then conducts, and capacitor C_F charges. The output voltage, U_o , is determined by

$$U_o = [-U_b t_i / t_o] V$$

where U_b is the supply voltage; t_i is the time the transistor is switched on; t_o is the time the transistor is switched off. Period t_i is determined by the value of C_T .

The output voltage is divided across $R1$ and $R2$ and applied to the inverting input of an on-chip comparator, whose +input is a 1.2 V reference voltage. When the actual value of U_o lies below the wanted value, the comparator toggles and switches on the oscillator, which in turn drives the transistor.

The TL 497A also contains a current limiting circuit which ensures that the coil cannot be saturated and that that



transistor is not affected by voltage spikes.

Coil L may be any fixed inductor with a value of 100...500 μ H.

The output voltage is calculated from $U_o = -[N+1.2]V$

where N is the numerical value of $R2$ in kilohms.

The output current should not exceed 50 mA.

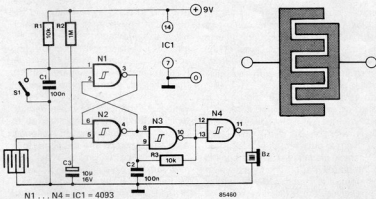
Texas Instruments Application



water-diviner

This little unit may be used to give an audible alarm when, for instance, a washing machine hose has burst, or when it starts to rain so you can get the washing in, or it can call you to the bathroom to turn the bathwater off. No doubt you will be able to think of some more uses.

The circuit may be powered from a 9 V battery which, since the current consumption is very low, will last for at least a year. After a year it should be replaced because it will then become unreliable owing to its self-discharge. Basically, the unit consists of a sensor, an R-S bistable, an oscillator, and a



driver stage for the alarm buzzer. The sensor consists of a waste piece of wiring board, about 40×20 mm. Connect all odd and all even tracks together with wire links, that is, 1 to 3 to 5, and 2 to 4 to 6. Tin the tracks to protect them against corrosion. When the board is dry, the resistance between the two sets of tracks is high, but when it is wet, the resistance drops sharply. The sensor is in series with resistor R_2

and the two together, therefore, form a humidity-dependent voltage divider, which resets the R-S bistable when input 1 of N_2 goes low. Oscillator N_3 is then switched on, and driver N_4 energizes the buzzer. The bistable is set automatically on power up via the series combination R_1 and C_1 . The circuit can also be used as a lie-detector. The sensor is then replaced by two lengths of wire of which the

ends have been stripped. The bare wires are then placed in the hands of the person being interrogated. If the lies (which causes his hands to become damp) the buzzer will sound. The sensitivity of the circuit is determined by the value of R_2 ; some experimenting may be necessary here. The oscillator (and, therefore, the buzzer) is disabled by closing switch S_1 .

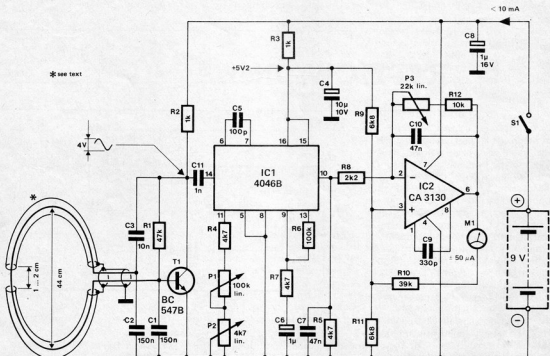


metal detector

In contrast to the other metal detector in this issue, the present one works on the principle that the frequency of an LC oscillator changes when the inductance is altered. Any metal object brought near the inductor will modify the inductance. The degree by which the frequency changes depends on the nature of the metal and on the frequency. If the frequency is very high, a metal object will act as a shorted turn, which lowers the inductance, so that the frequency increases. If the frequency is low enough for eddy-current losses to be ignored, it is possible to distinguish ferrous from non-ferrous metals. The inductance required for an oscillator frequency of not greater than 200 Hz would be pretty difficult to make, and the oscillator in the present

circuit, therefore, works at about 300 kHz. The inductance then needed is quite easy to make and consists of a single turn of coaxial cable as shown in the accompanying diagram. The circuit consists of oscillator T_1 , frequency-to-voltage converter IC_1 , and BiMOS operational amplifier IC_2 . With a detector coil diameter of c. 440 mm, the values of capacitors C_1 and C_2 ensure an oscillator frequency of around 300 kHz. Smaller diameter coils need more turns. The level of the oscillator signal should be at least 500 mV_{pp} to be able to drive the 4046B satisfactorily. At that level, the phase comparator ensures that the internal phase-locked loop always locks. The source follower output at pin 10 is fed to a CA3130 where it is amplified substantially.

The centre frequency of the phase-locked loop, and, therefore, the zero of the centre-zero microammeter, is set with P_1 ; fine adjustment with P_2 may be necessary if the sensitivity of the opamp is high. That sensitivity is set with P_3 which is connected in the negative feedback loop to the inverting input. There is also positive feedback via the microammeter and R_{10} to the non-inverting input. If, therefore, a meter with a different resistance is used, it may be necessary to alter the values of R_9 , R_{10} , and R_{11} accordingly. Note that in treasure hunts the size of the objects sought should have some relation to the diameter of the detector coil: looking for coins with a 440 mm (17.5 in) diameter coil is a fruitless task!

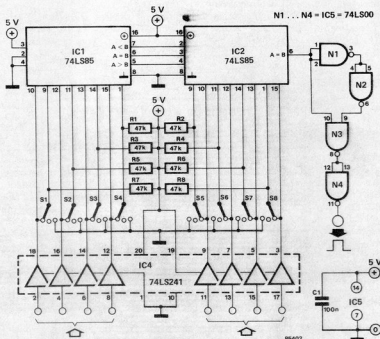


simplified word comparator

Primarily intended as a trigger source for an oscilloscope in the testing of digital circuits, the comparator is a derivative of the *word recognizer and delayed trigger* published in the July/August 1981 issue of *Elektron*. When an 8-bit binary word is recognized during a comparison with a pre-determined value, the present circuit issues a short trigger pulse. In contrast to the original circuit, the present one has no provision for either a delayed trigger pulse or an external trigger input. None the less, the comparator remains an almost indispensable aid in the testing of digital circuits.

The unit is based on two four-bit comparators, IC₁ and IC₂. The reference level for them can be set separately with switches S₁...S₄ and S₅...S₈ respectively. With these switches set as drawn, inputs A and B are interconnected: this is the don't care position. With a switch set to its centre position, a high reference level is obtained, while when it is set to the extreme right position, a low reference level is obtained.

When all A and B inputs agree, the A=B output of IC₂ goes logic high. Gates N₁...N₄ suppress short spurious pulses that arise during the stabilization of the comparator inputs. The size of the binary word can be increased by cascading two or more comparators. Account must then be



taken of the transit delay which amounts to 24 ns per comparator. In some tests this may lead to an unacceptable delay if several comparators are used.

The current consumption is about 60 mA per comparator: 32 mA is

drawn by the LS241, and 10 mA by the LS85. This enables the current consumption of multiple comparators to be calculated quite easily.

Note that each additional IC must be separately decoupled by a 100 nF capacitor.

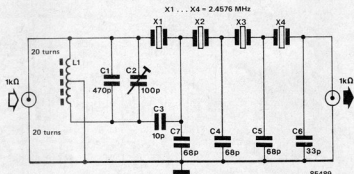


RTTY/CW filter

An appreciable part of short-wave radio traffic takes place via morse and radio teletype transmission. To ensure optimum reception of these types of transmission, a practical bandwidth of about 300 Hz is required in the receiver. Such a bandwidth allows for some drift of both transmitter and receiver, and also for the frequency shift of RTTY signals. As commercially available filters meeting these requirements are still rather expensive, it pays to build your own: a suitable one is shown in the accompanying diagram.

The crystals used are inexpensive types, commonly found in computer systems.

Inductor L₁ is made by winding 2 times 20 turns enamelled copper wire of 0.3 mm diameter onto a T50/2 RF



L1 = 2 x 20 turns enamelled copper wire of 0.3 mm dia. on type T50/2 RF toroid

toroid (available from Cirkuit).

Some parameters of the filter are:

■ bandwidth at -6 dB points - 300 Hz

■ bandwidth at -60 dB points - 1100 Hz

■ insertion loss - 7 dB

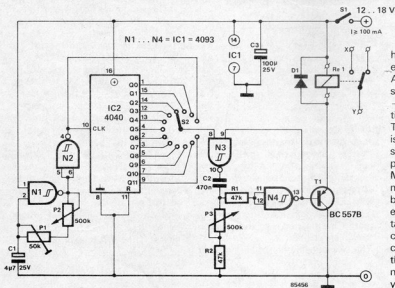
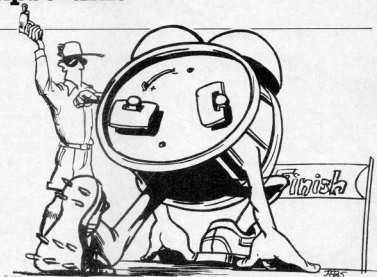
■ ripple in pass-band - <1 dB



time-lapse unit

Which amateur film maker has not wished sometime that he could experiment with time exposures? Fortunately, it is now possible with a simple electronic circuit to see the grass grow without having to sacrifice a night's sleep.

The circuit consists of a clock oscillator, N_1 - N_2 , a 12-stage binary counter, IC_2 , and a monostable, N_3 - N_4 . Preset P_1 is adjusted to make the highest oscillator frequency about 16 Hz. When switch S_2 connects pin 4 of N_2 to pin 8 of N_3 , the circuit works in "real time". Each successive step of S_2 from this position doubles the time between exposures. At the minimum oscillator frequency of 0.5 Hz, and S_2 connected to the Q_{11} output of IC_2 , intervals of up to two



hours are possible between exposures.

As the signal at the wiper of S_2 is a square wave, which is — by definition — logic 1 for half the time, it is essential that it is shaped in a monostable. The duration of the consequent pulses is determined by P_3 . Their width should, of course, not exceed the period of the clock oscillator.

Many film cameras are provided with a miniature socket via which they can be operated for single frame exposures and film transport. Contacts X and Y of relay Re, should be connected to this socket via a suitable cable. If you have any trouble with this, or are not sure of the socket connections, it is best to seek advice from your local photographic dealers.



opamp tester

All types of operational amplifier can be functionally checked with the tester proposed here.

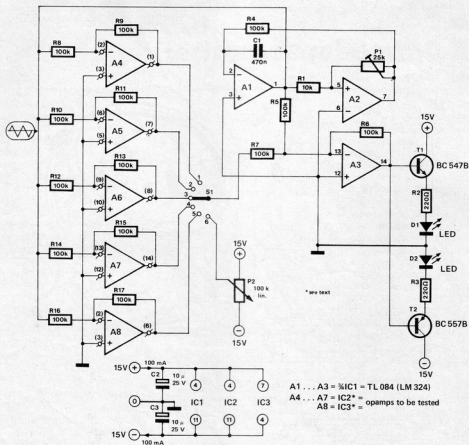
The principle of the tester is quite simple: a triangular voltage is applied to the inverting (—) input of the specimen. This voltage is, of course, inverted. If then the inverted and the original triangular voltage are added, the result should be zero. Any deviations from this are taken as a malfunction which is indicated by one of two light-emitting diodes (LEDs). The

tester has, of course, a self test facility so that the error-free operation of it can be readily ascertained.

Opamps A_1 and A_2 form a triangular pulse generator. Opamp A_1 operates as an integrator: capacitor C_1 is charged, and as soon as the voltage across it reaches the threshold value of Schmitt trigger A_2 , resistor R_1 is connected to earth, and C_1 discharges until the voltage across it reaches the second threshold of A_2 , when the process repeats itself.

Opamp A_3 functions as the summing stage whose output is fed to two transistors that drive LEDs.

The specimens are connected as inverters in either positions Ap_1 , Ap_2 , Ap_3 or Ap_4 . In the design it was assumed that the most frequently encountered opamps are contained in a 14-pin DIL housing (as, for instance, the TL084 used for A_1 ... A_3), or in an 8-pin DIL package (such as the LM355 or LM387). For different packages, the specimen connections



in figure 1 should be modified accordingly.

When a specimen is defect, the output of A_3 consists of a triangular voltage superimposed on the (DC) offset. This is sufficient to bias the drive transistors and one or both LEDs flash in rhythm with the triangular voltage. The frequency of that signal is about 10 Hz, and this can be altered to some extent by changing the value

of R_4 and/or C_1 .

It is clear that the voltage at the output of A_3 must be greater than ± 0.6 V, otherwise the bias for the transistors is too small. Preset P_1 should therefore be adjusted so that the LEDs just do not light when an opamp that is known to work correctly is inserted in the relevant specimen position.

The self test function is easily check-

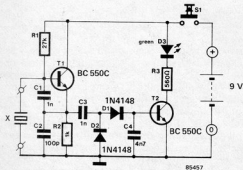
ed: when P_2 is turned from one extreme of its travel to the other, first one LED, then both, and finally the other LED should light.

In positions 1...4 of switch S_1 , the four opamps contained in, say, a TL 084 can be tested sequentially; in position 5, the single opamp contained in, say, an LM 355; and position 6 is the self test setting.



crystal tester

Many electronics hobbyists have crystals lying about, but don't know whether these are still working all right. The crystal tester described here will quickly show whether a crystal can be used or should be discarded. Transistor T_1 and the crystal under test form an oscillator. Capacitors C_1 and C_2 form a voltage divider in the oscillator circuit. If the crystal is in good order, the oscillator will work. Its output voltage is then rectified and smoothed by D_1 and C_3 respectively. The resulting direct voltage at the base of T_2 is sufficient to switch this transistor on, so that the LED lights.



The circuit is suitable for use with crystals of a frequency between 100 kHz and 30 MHz. Current consumption is about 50 mA.

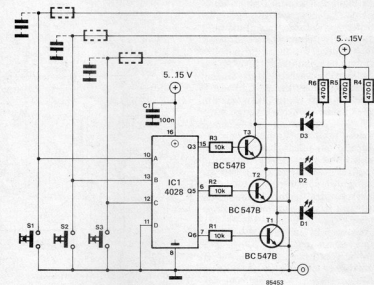


metering selector

When just one meter is used to measure the voltage of three different sources, it is, of course, possible to use a three position rotary switch to select any one of the sources. However, care must be taken here, because the switch must break before make, otherwise two sources are interconnected and this is normally highly undesirable.

Any electronic equivalent of the rotary switch must, of course, also break before make. Unfortunately, transistors have the property of switching on much faster than switching off. For example, a well-driven BC 547 takes a couple of μs to switch off, but far less than that to switch on.

The present circuit circumnavigates these potential troubles by using the output level as criterion, whereby a 4028 serves as the referee. The 4028 is a one-of-ten active high decoder which drives one of three transistors, $T_1 \dots T_3$. Let us assume that T_1 is on: its collector voltage is low, and so is input A of the 4028. The other two collectors are high, and so are inputs B and C of the decoder. The 4028 therefore sees binary code 6 (110) at its input and this causes pin 6 to go logic high, so that T_1 is driven hard. When in this condition another key, for instance, S_2 , is pressed, a wrong code, i.e., 4 (100), ensues. Output 4 of the 4028 is, however, not connected, T_1 switches off, but T_2 is not yet driven. Only after T_1 has actually



switched off, and its collector goes high, does 5 (101) arise at the input of the 4028; T_2 will then be driven.

In practice, the voltage at the collector may be used to control a CMOS switch that arranges the change over of the meter or the sound channel. It is also possible to replace the collector resistor by a suitable relay, but this would, of course, introduce even longer delay times (of the order of milliseconds). In that case, the feedback to the input must be effected by a separate contact of the relay, but

there is then, of course, absolute certainty that switching is correct!

Another variant is including a resistance in each feedback loop and shunting each switch contact by a capacitor. This RC network will ensure a reasonable delay during the change over.

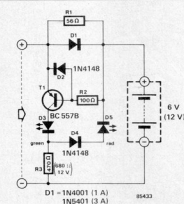
Current consumption of the 4028 is small (CMOS!), while that of the transistors depends on the value of the collector resistors. With values as shown, it amounts to 18 mA for a supply voltage of 10 V.



battery charging indicator

Sealed 6 V or 12 V lead-acid batteries, under normal charging conditions, are charged at a constant voltage of 2.3 V per cell. The charging current reduces during the charging: when it reaches a value of 10 mA, the battery is deemed fully charged. To check this, you do not need an expensive ammeter. The present circuit uses an LED (light-emitting diode) to indicate when the battery is fully charged.

The green indicator LED is connected in the collector circuit of a p-n-p transistor. As soon as the transistor conducts, the LED lights. This happens when the voltage drop across resistor R_1 reaches the forward bias threshold of the base emitter junction (about 0.6 V). When this resistor has a value of 56 Ω , a charging current of around



10 mA will cause this drop. To ensure that the charging current can exceed

10 mA, R_1 is shunted by diode D_1 , which limits the voltage drop across the resistor to about 0.7 V. The maximum charging current depends on the diode used and lies between 1 and 3 A.

The LED does not light when the charging current is less than about 10 mA, i.e., when the battery is fully charged, when the battery is connected with wrong polarity, or when the output is short-circuited. The red LED will light when the battery is connected with reverse polarity.

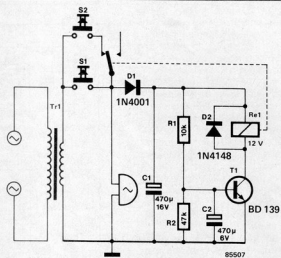
The indicator should be connected between the charger and the battery. It may either be built into the charger housing, or be constructed in a small case that can conveniently become part of the charging cable.



twin bell-push

It is often desirable for a single doorbell to be operated by two bell-pushes, for instance, one at the front door and the other at the back-door. The additional bell-push, S_2 , in series with the break contact of relay Re_1 , is connected in parallel with the original bell-push, S_1 . When S_2 is pressed, the bell voltage is rectified by D_1 and smoothed by C_1 . After a time $\tau = R_1 R_2 C_2$, the direct voltage across C_2 has risen to a level where T_1 switches on. Relay Re_1 is then energized and its contact breaks the circuit of S_2 , so that the bell stops ringing. After a short time, C_1 and C_2 are discharged, the relay returns to its quiescent state, and the bell rings again.

In this way, S_1 will cause the bell to ring continuously, while S_2 makes it ring in short bursts, so that it is immediately clear which bell-push is operated.



Tr1 = bell transformer



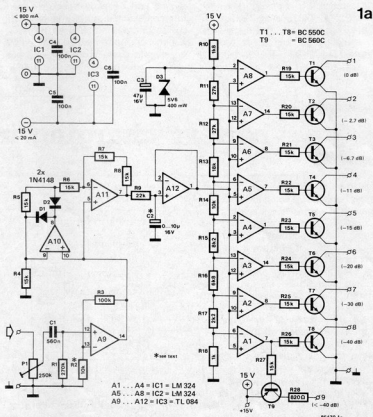
sound-level indicator

This novel indicator is ideally suitable for use in a discotheque. It consists of eight equi-distant columns of eight LEDs arranged in a starlike pattern, so that corresponding LEDs in the eight columns form concentric circles, as shown in figure 1b. The higher the sound level, the more circles light, giving the impression of a star of constantly varying brightness.

As can be seen in figure 1b, the eight LEDs in any one of the eight circles are connected in series. Each of these series chains is driven by a transistor: $T_1 \dots T_8$ in figure 1a. Dropping resistors are not required: the positive supply voltage provides just over 1.8 V per LED, which is a perfect value for red LEDs to show up nicely.

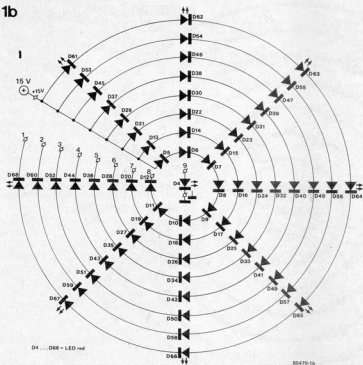
Transistors $T_1 \dots T_8$ are driven by differential amplifiers $A_1 \dots A_8$, which compare the audio-dependent direct voltage across C_2 , which is buffered by A_{12} , with the potential determined by D_{11} and $R_{11} \dots R_{18}$. If the result of the comparison is positive, the associated driver transistor is switched on, and the appropriate circle of LEDs lights. The LED in the centre, D_{11} , is driven by T_9 , and only lights when the sound level is very low.

The direct voltage across C_2 results from full-wave rectification in A_{10} and A_{11} of the input signal after this has



A1 ... A4 = IC1 = LM 324
A5 ... A8 = IC2 = LM 324
A9 ... A12 = IC3 = TL 084

1b

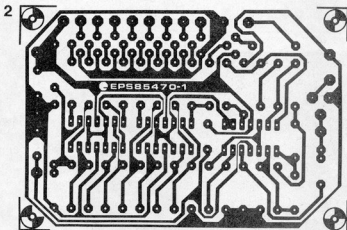


been amplified in A_3 . The input sensitivity is about 600 mV for saturation, i.e., to light all sixty-four LEDs; it can be increased by lowering the value of R_2 .

The speed with which variations in sound intensity are indicated depends on the value of C_2 ; if this is 10 μF , the light pattern changes slowly, whereas when the capacitor is omitted, it reacts instantly to different sound levels.

The indicator is constructed on two printed circuit boards (figures 2 and 3). The LED board in figure 3 has not been provided with a component layout because of aesthetic considerations. The layout is, however, given on the PCB in figure 4 for those who want to use it all the same. The two boards can be fitted together with the use of spacers: appropriate holes have been provided for this in a manner which ensures that the 11 terminals for interconnections on the boards are opposite one another.

An interesting optical effect arises when a sheet of red perspex is mounted in front of the LED board. Refraction in this material causes the LEDs to show up as sources of diffused, rather than pinpointed, light. The current consumption of 800 mA at saturation may be reduced by lowering the supply voltage to, say, 12 V, but this will, of course, reduce the brightness of the display.



Parts list

Resistors:

- $R_1 = 270 \text{ k}$
- $R_1^*, R_{14} = 10 \text{ k}$
- $R_3 = 100 \text{ k}$
- $R_4 \dots R_8, R_{19} \dots R_{27} = 15 \text{ k}$
- $R_9 = 22 \text{ k}$
- $R_{10} = 1 \text{ k}$
- $R_{11}, R_{12} = 27 \text{ k}$
- $R_{13} = 18 \text{ k}$
- $R_{15} = 8 \text{ k}$
- $R_{16} = 6 \text{ k}$
- $R_{17} = 2 \text{ k}$
- $R_{18} = 1 \text{ k}$
- $R_{28} = 820 \Omega$
- $P_1 = \text{preset potentiometer, } 250 \text{ k}$

Capacitors:

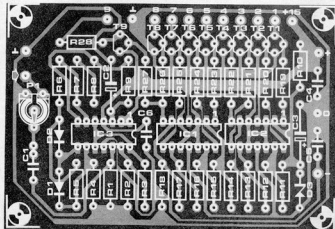
- $C_1 = 560 \text{ n}$
- $C_1^* = 0 \dots 10 \mu / 16 \text{ V}$
- $C_3 = 47 \mu / 16 \text{ V}$
- $C_4 \dots C_6 = 100 \text{ n}$

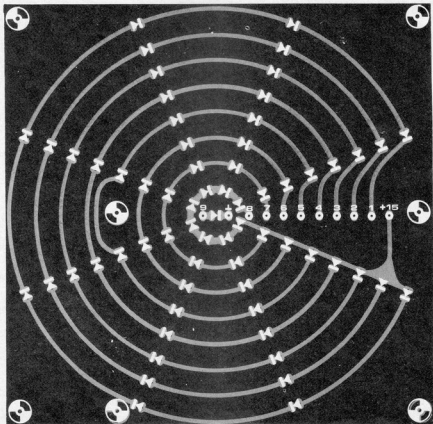
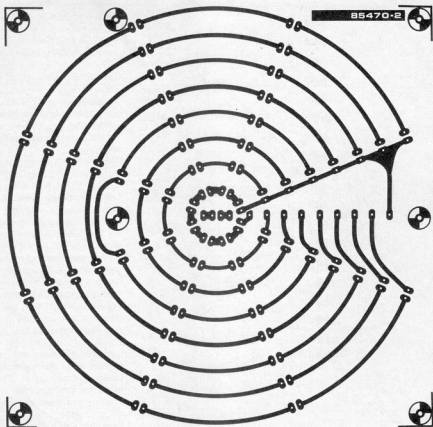
Semiconductors:

- $T_1 \dots T_8 = \text{BC550C}$
- $T_9 = \text{BC560C}$
- $D_1, D_1 = 1\text{N}4148$
- $D_3 = \text{zener diode } 5\text{V}6/400 \text{ mW}$
- $D_4 \dots D_{68} = \text{LED red}$
- $\text{IC}_1, \text{IC}_1 = \text{LM324}$
- $\text{IC}_3 = \text{TL084}$

* = see text

For Components Sources
See Page 9-38







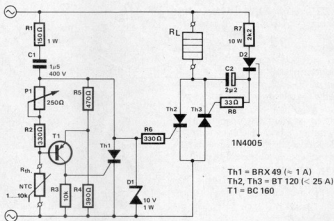
temperature regulator with zero crossing switch

This temperature regulator can be built without special ICs and may be used with powers up to 3.5 kVA.

The circuit is based on a two-point regulator with a thermistor as the temperature sensor. As the load current is switched only during zero crossing of the mains, no additional interference suppression is necessary.

The series combination $R_1 C_1$ serves to lower the mains voltage to a level suitable as supply voltage for trigger T_1 . As R_1 is small compared with the reactance of C_1 , the current leads the voltage by nearly 90° .

If the ambient temperature is higher than a given value, determined by potentiometer P_1 , the resistance of R_{th} is low enough to cause T_1 to conduct. Silicon controlled rectifier Th_1 is supplied with gate current and switches on during the negative half cycle of the mains, because the current through $R_1 C_1$ leads the voltage. When Th_1 is on, thyristors Th_2 and Th_3 remain in the blocked state, so that no current flows through heating element R_L .



85437

When the temperature drops below the value determined by P_1 , transistor T_1 and thyristor Th_1 remain off, so that Th_2 conducts. As the voltage across zener diode D_1 leads the mains voltage, Th_2 switches on when the remains crosses zero. At the onset of

the negative half cycle, Th_3 switches on.

During the positive half cycle, C_2 is charged via R_7 and D_2 , and so provides the gate current to switch on Th_3 at the onset of the negative half cycle.



economical power supply

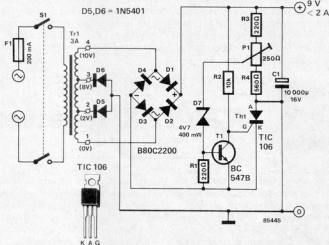
The power supply described here uses a silicon-controlled rectifier (SCR) that, depending on the load current, selects taps on the secondary of the mains transformer. The output voltage of around 9 V is eminently suitable as input voltage for a 5 V regulator, which consequently works with the absolutely minimum power dissipation.

With low to medium load currents, the SCR is in the blocking state. Rectification of the secondary transformer voltage then takes place in D_1 , D_2 , D_3 , and D_6 only. The load current flows during the positive half cycle via D_1 , load, and D_5 ; during the negative half wave it flows through D_2 , load, and D_6 . The tapped secondary voltage amounts to 8 V in either case, while a 2 V section remains unused.

With increasing load current, the output voltage drops until no current flows any more through the zener diode. Transistor T_1 switches off which removes the short circuit from the gate of the SCR, which then conducts. As soon as that happens, the full secondary transformer voltage is rectified by $D_1 \dots D_4$, while diodes D_5

and D_6 are reverse biased. As the voltage across the zener diode is always lowest during the zero crossing of the secondary voltage, the SCR always switches on at or near that instant. This prevents high current pulses and other noise often associated with SCR switching; no further

suppressors are therefore necessary. To build this supply, you need a mains transformer with a 12 V secondary that has taps at 2 V steps: 2.4-6.8-10-12 V. For load currents up to 1.5 A, a 2 A transformer will suffice; an output current of up to 2 A requires a 3 A transformer.



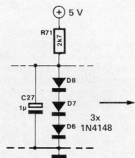
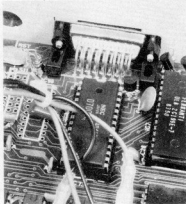
85445



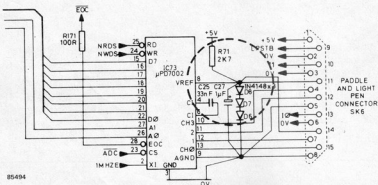
measuring with the BBC micro

The BBC micro, one of the best value-for-money computers on the market, can be used for a variety of applications thanks to the various interfaces provided as standard. The four analogue inputs, each with a resolution of 10 bits, make it particularly suitable for measuring all kinds of processes.

There is unfortunately one drawback: the rather poor reference voltage associated with the analogue inputs. That voltage is obtained from three normal diodes connected in series. The alternative described here has been in use in our BBC micro for some time.



LM 336Z



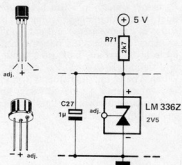
85494

Diodes $D_6 \dots D_8$ in the diagram provide a reference voltage of 1.8 V, which is fine for use with a joystick interface, but will not do where absolute values are to be measured. The three diodes are, therefore, replaced by one zener diode, a 2.5 V type LM336Z. This diode deviates no more than 1.8 mV over the temperature

range of 0...70 °C; its long-term stability is better than 20 p.p.m. at 25 °C. Its internal resistance is 0.4 Ω, which makes it ideal for our purpose. Moreover, it is easily fitted into the micro without the need for any alterations other than the removal of $D_6 \dots D_8$. The micro remains, of course, fully compatible with existing

software.

Cut off the adjust terminal from the LM336Z, and unsolder $D_6 \dots D_8$ from the computer. Solder the anode and cathode of the zener to the cathode connection of D_6 and the anode connection of D_8 respectively. A good-quality small soldering iron is indispensable here!



NAVTEX receiver

NAVTEX, the international maritime service that provides navigational and meteorological information via RTTY (radio teletype) on 518 kHz, makes use of FECTOR. This is a system in which the information is transmitted twice, with a particular interval between the first character and the repeat. FECTOR is decoded automatically by a microprocessor that is coupled to the ship's medium wave receiver.

It is, of course, not desirable that the decoder is taking up the medium wave receiver continuously. On the other

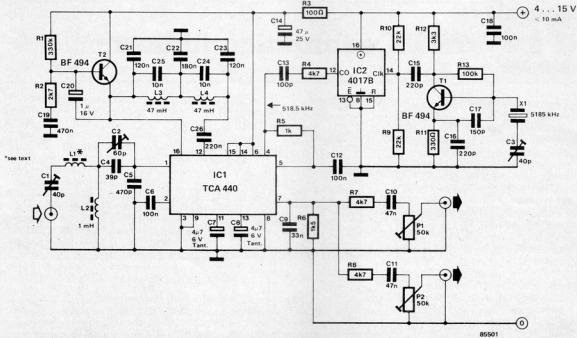
hand, navigational officers, and many amateur radio listeners, do not want to miss one iota of NAVTEX information. Obviously, a second receiver is the answer, and this can, of course, be coupled to the decoder night and day. Since only one frequency, 518 kHz, and one type of transmission, FSK (frequency shift keying), needs to be received, the circuit can be kept quite simple.

The circuit is based on a type TCA440. The AGC (automatic gain control) provided by this IC is not used because the IF amplifier, due to its

internal symmetry, is already an excellent limiter for FSK signals.

The internal oscillator is not used either: it is replaced by a crystal oscillator, T₁, operating on 5185 kHz, that is followed by a decade scaler, IC₂. The exact frequency of the crystal depends on the requirements of the decoder; trimmer C₂ enables it to be varied by a few kHz, i.e., a few hundreds of Hertz at the output.

Thanks to the TCA440, the remainder of the receiver is fairly simple without the need of special components. Standard chokes can be used in the



L_2 ... L_4 positions; L_1 consists of 6 turns enamelled copper wire of 0.3 mm dia. on a ferrite bead. Sensitivity of the receiver is good at a few μV . Calibration is very simple: adjust input trimmers C_1 and C_2 for maximum out-

put, and then turn C_3 until the output frequency matches the decoder. The crystal should be suitable for parallel resonance with a capacitance of 30 pF. Current consumption is not greater than 10 mA. The supply voltage may

be 4...15 V. It is, of course, a fairly simple matter to make the receiver suitable for use on other maritime medium wave lengths.

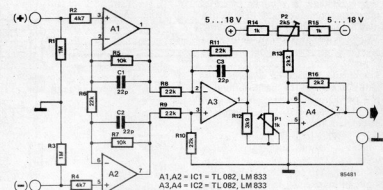


meter amplifier

A meter amplifier is intended for use between a sensor or other measuring device, such as a probe, and the indicator. It is characterized by a high input impedance, typically 1 M Ω , and a differential input. A differential input ensures that the output signal cannot be affected by hum or noise on the meter leads.

The input signals are buffered by differential amplifiers A_1 and A_2 . The 22 pF capacitors in the C_1 and C_2 positions obviate any tendency to oscillate. The output of opamp A_3 is a function of the difference between the two input signals. Opamp A_4 serves to compensate for any offset and also to set the amplification at exactly 1. The bandwidth of the circuit as shown is not less than 100 kHz, and the phase shift is 0 $^\circ$.

As already mentioned, the amplifier may be used with any sensor, for instance, in computer control of the central heating, or to monitor the ambient temperature in rooms. It can also be used with a multimeter or oscilloscope.



The peak-to-peak level of the input signal should not exceed about 80 per cent of the supply voltage. Current consumption is not greater than 25 mA at a supply voltage of $\pm 18\text{ V}$. Calibrate the unit by adjusting P_2 under no-signal conditions for zero

output, and setting the amplification to exactly 1 with P_1 . If you aim at perfection, use 1 per cent resistors.

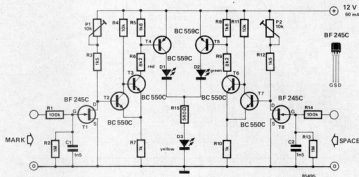


RTTY calibration indicator

To calibrate an RTTY (radio teletype) decoder correctly in accordance with the marks and spaces, an oscilloscope is needed. The mark and space signals are applied to the X and Y inputs of the instrument respectively, when, on correct calibration, the screen of the oscilloscope displays the well-known RTTY cross.

If an oscilloscope is not available, the circuit shown here can be used. It consists of two amplifiers with high-impedance input, T_1 and T_2 , that are followed by driver stages $T_3 \dots T_4$ and $T_5 \dots T_7$. The driver stages control three LEDs, $D_1 \dots D_3$ direct. Diode D_1 (red) is the mark indicator, D_2 (green) is the space indicator, and D_3 (amber) indicates whether the decoder has been calibrated symmetrically.

Preset potentiometers P_1 and P_2 determine the amplification of the field-effect transistors. Proper setting of these components enables the indi-



calator to be matched with the filter outputs of any RTTY decoder.

After the indicator has been coupled to the RTTY decoder, that unit can be calibrated as follows:

■ tune the short-wave receiver to the marks; the BFO knob must be adjusted until the red and amber LEDs

both flash brightly;

■ the RTTY decoder is then adjusted to the correct frequency deviation, indicated by the flashing of the green LED. If the amber LED lights continuously, the decoder has been calibrated correctly. Otherwise, the above procedure should be repeated carefully.



thrifty LED indicator

It is often necessary that the current consumption of an essential status indicator is minimal. In the circuit shown, dependent on the level of the supply voltage, a number of LEDs drawing a current of only 10...15 mA may be switched on or off as desired. Moreover, the entire indicator may be switched off if none of the LEDs lights.

The circuit is based on switched current source T_1 . The base current of this transistor is set at c. 15 mA with R_2 . The value of this resistor is calculated from $R_2 = [4 \times 10^3 / (U_b - 0.7)] \Omega$ where U_b is the supply voltage in volts.

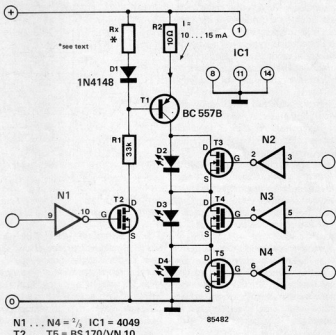
Transistor T_2 conducts when the input to inverter N_1 is logic 0: when this becomes a logic 1, the current source and, consequently, the indicator are switched off.

If the input to one of the buffers $N_2 \dots N_4$ is a logic 1, the associated LED is switched on.

More LED-FET combinations may be added to the circuit as long as the supply voltage permits this. Also, the dissipation of T_1 has to be kept within certain limits. A BC557B can be used for T_1 over the supply voltage range of 5...18 V.

The circuit is intended for CMOS ICs; if devices of other logic families are used, remember to take account of the different logic threshold levels.

Note that the buffers must be powered from the same supply as the current source.



$N1 \dots N4 = \frac{1}{2}$ IC1 = 4049
 $T2 \dots T5 = BS 170/VN 10$

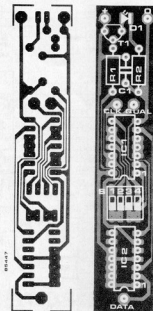


faultfinding probe for μ Ps

Anyone who has ever tried to faultfind in a microprocessor system with a test probe will have experienced the uselessness of it. This is because the signals at the address, data, and control buses are constantly — and rapidly — changing. This means that it is not just the signal level that is important, but also the instant the signals are present. For faultfinding properly, you need a logic analyser, which is capable of indicating several signals simultaneously.

If you have no logic analyser, the probe presented here may provide the solution. Strictly speaking, this is nothing more than a bistable multivibrator (FF.). Data are simply read direct and cause D_1 to light or stay out, depending on the state of FF₁. The bistable only reads at the instant its clock input (pin 3) switches from low to high.

The clock signal is thus the key for all measurements carried out with the probe and that means it must be chosen with some care for every test. Suppose you have to check whether a certain portion of memory is all right. The \overline{CE} signal in the memory is then connected to the QUAL input of the probe. Switch S_4 must be closed, because \overline{CE} is active low. The probe can then only read data during a \overline{CE} of the RAM under test. The CLK input of the probe is connected to the \overline{RD} signal of the memory. Reading must then be carried out during the trailing, i.e., the positive-going, edge. Switch S_1 must, therefore, be closed.



Parts list

Resistors:

$R_1 = 10 \text{ k}$

$R_2 = 390 \Omega$

Capacitors:

$C_1 = 100 \text{ n}$

Semiconductors:

$D_1 = \text{LED, red}$

$T_1 = \text{BC557B}$

$IC_1 = 74LS00 \text{ or HC(T)}$

$IC_2 = 74LS74 \text{ or HC(T)}$

Miscellaneous:

$S_1 \dots S_4 = 4\text{-way DIL switch}$

For Components Sources See Page 9-38

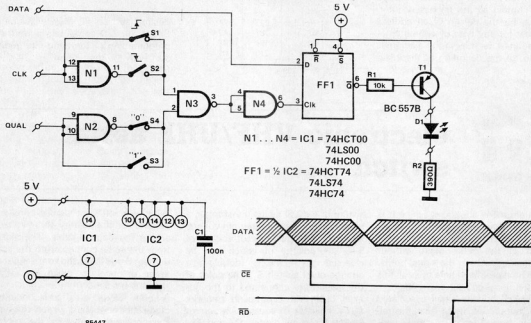
Reading is effected by, for instance, a PEEK command in BASIC. Diode D_1 will then light in accordance with the signal emanating from the RAM during this process.

Be careful that this BASIC is not used by the RAM section being tested, because then there will be more than one read process and the probe will only retain the last of these. There is no easy solution in that case, but often it will be possible with the aid of a monitor to make the microcomputer execute only one command in machine language.

To keep the probe small, DIL (dual in line) switches are used in the $S_1 \dots S_4$ positions. Note that only S_1 or S_2 and S_3 or S_4 should be closed simultaneously at any one time.

LS type ICs may be used, but as these put a relatively high load on the circuit during tests, HCT types are better. These are fully compatible with the LS types but have high impedance inputs. HC types should only be used where systems are already executed entirely in CMOS; the supply voltage can then be higher than 5 V.

Current consumption of the circuit is small: 10 mA for the LED and 5 mA for the ICs (if these are TTL).





programmable baud-rate generator

Only some computers, e.g., the Samson 65, enable you to reprogram the ACIA (asynchronous communications interface adapter), or whatever your serial interface may be, if you want to connect a printer and a modem to your computer. With most other micros, you have to use an additional circuit like the one proposed here.

The circuit is based on a presetable, synchronous down counter, a CMOS IC type 40103. Another CMOS IC, type 4060B, serves as a crystal controlled clock generator. The crystal frequency, f_x , is 2.4576 MHz, while the clock, f_c , is 153.6 kHz. The output frequency, f_o , of the generator is determined from

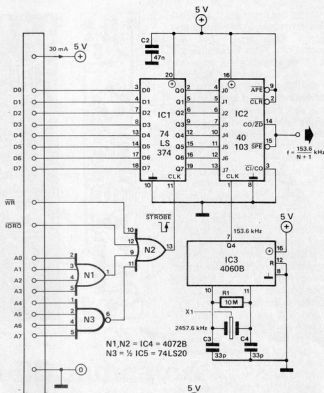
$$f_o = [153.6 / (N + 1)] \text{ kHz}$$

where N is the decimal equivalent of the number that is input to the $J_0 \dots J_7$ terminals of the 40103 (see table).

The number N is provided by the computer and from there written into, and stored by, the 74LS374. The table gives various baud rates (also for RTTY — radio teletype) and the corresponding decimal and hexadecimal numbers.

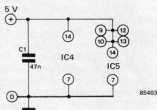
The address decoder in the circuit diagram is arranged for a Z80 computer, as can readily be seen from the control signals, but this is purely taken as an example. The signal from the data bus is applied to the 74LS374 at the leading edge of the STROBE pulse at the output of the decoder. The articles *address decoding* and *memory timing* in the February and March 1984 issues of *Elektron* respectively contain all the necessary information for the design of an address decoder for any type of computer.

The address decoder in the diagram is shown for the decoding of the hexa-



baud-rate	N (dec)	N (hex)
4800	1	01
2400	3	03
1200	7	07
600	15	0F
300	31	1F
150	63	3F
110	86	56
100	95	5F
75	127	7F
57	167	A7
50	191	BF
45.45	210	D2

$$1 \leq N \leq 255$$



decimal address F0. Many versions of BASIC on Z80 computers permit the programming of the baud-rate generator with the instruction OUT 240, N



electronic VHF/UHF aerial switch

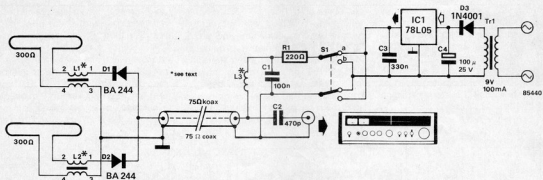
There are many situations where it is useful, or downright essential, to be able to switch between two VHF/UHF aerials at the aerial mast without introducing losses in the signal paths. The switch proposed here does all this over the usual coaxial down lead.

The switch and its small associated power supply are fitted near the relevant receiver. The power supply, con-

sisting of a small mains transformer, a rectifier diode, and a three-pin voltage regulator, provides a direct voltage of 5 V, the polarity of which can be reversed by DPCO (double-pole change-over) switch S_1 . The poles of the switch are connected to the coaxial cable via decoupling network L_3 - C_1 . Resistor R_1 serves as a current limiter for p-i-n diodes D_1 and D_2 .

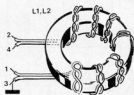
Whichever of these diodes conducts depends on the polarity of the voltage across the coaxial cable. The signal from the aerial connected to the conducting diode is passed to the input of tuner or receiver, while the other signal is blocked.

A p-i-n diode is a semiconductor diode that contains a region of i-type semiconductor between the p-type



and n-type regions. They are invariably used as switching diodes. Their most important property is a very low self-capacitance, while at high frequencies they are virtually purely resistive (see *Elektron*, July 1983, p. 7-26). Choke L_3 is made from four turns enamelled copper wire of 0.3 mm dia. around a ferrite bead. If the aerials have no 75 Ω termination, this may be

provided by L_1 and L_2 which convert the 300 Ω balanced aerial impedance to the asymmetrical 75 Ω required by the receiver input. These inductors are made by winding 7 turns of two-core flat cable on a T50-2, T50-3, or T50-6 toroid as shown in figure 2. If the switch is mounted in the open, it should be well protected from the elements: potting in araldite is best.



audio transfer equalizer

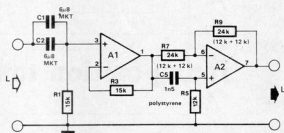
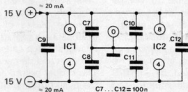
Limiting the bandwidth of an audio system to 20 kHz affects the behaviour of the system in the pass band. The steeper the filter characteristic, the greater the phase shift in the pass band. That phase shift stands in non-linear relation to the frequency, and this causes a frequency-dependent delay of the signals (increasing with frequency from about 4...6 kHz). This effect is audible.

The CD (compact disc) player is an example of a system in which the bandwidth has been so limited. Particularly the Sony CD player and its clones suffer from a frequency-dependent transfer time. The Philips (and Philips-derived) system does not suffer from this effect.

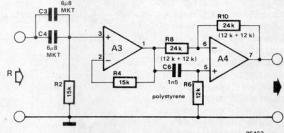
The effect can be negated by introducing a delay in the transfer time of the frequencies below 4...6 kHz, which equalizes the delay over virtually the entire audio range. In other words, transfer of all audio frequencies is carried out at the same speed as it should.

Such a delay is realized by phase shifter A_2 (left-hand channel) and A_4 (right-hand channel) in the accompanying figure. The maximum delay for the lowest frequencies is $2R_5C_5 = 2R_6C_6 = 36 \mu s$.

The circuit is connected between the output of the CD player and the AUX or CD input of the main amplifier.

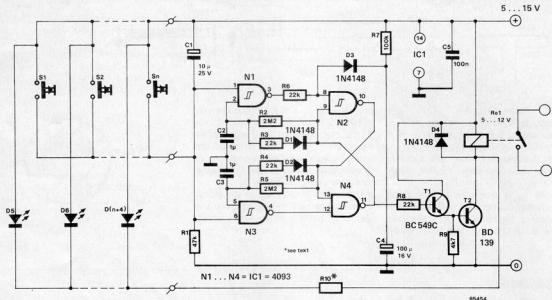


A1, A2 = IC1 = NE5532N
A3, A4 = IC2 = NE5532N





hotel switch



It is often required to switch an electric light or apparatus from various positions in a building. A typical example of this is the hotel switch, which makes it possible to control lights from a number of positions. With some electronics and electric wiring, the number of switching positions may be extended *ad infinitum*. The actual switching is effected by a relay that is controlled by an R-S bistable, N_2/N_4 , via transistors T_1 and T_2 . The state of the bistable is of import to the position of logic

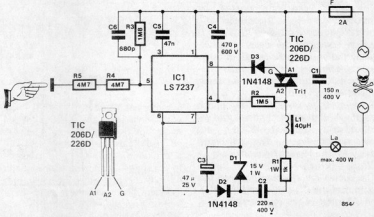
switches N_1 and N_3 . A trigger pulse at the junction of R_1 and C_1 is only applied to that input of the bistable which causes the bistable to toggle. In other words, a train of trigger pulses, 0;1;0;1;0... with a minimum interval between pulses of a few seconds, results in a series of logic level changes which causes the relay to be actuated and de-energized alternately. The trigger pulses arise when one of the push buttons, $S_1 \dots S_n$, is pressed briefly. The push buttons are all connected in parallel, so that they can be

interlinked by a two-wire system. It would be possible to fit an LED at every switch position, but this would entail an additional wire. Such LEDs would, of course, also be in parallel, so that it is advisable to use similar types. The value of resistor R_{10} is calculated from $R_{10} = ((U - 2)/I_D) \Omega$ where U is the supply voltage in volts; I_D is the current through each LED in A; and n is the number of LEDs.



four position touch dimmer

Any electric light may be adjusted with this dimmer to very low, low, medium and maximum, which in most cases will be sufficient. After all, it is all very well to be able to control an electric light over the whole range of its brightness, but how often is that facility really used? Moreover, in everyday use, position control has practical advantages: setting, for instance, takes a second or two. The circuit is based on an LS7237 and some discrete components. The dimmer may also be used as an electronic on/off switch, in which case the mode select pin (7) must be connected to earth (pin 1). Such a switch does not produce sparks and consequent noise in nearby electronic equipment.



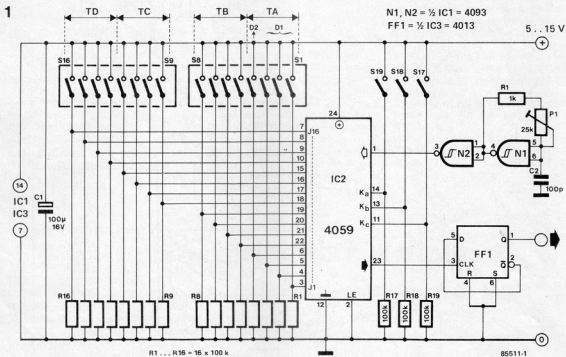
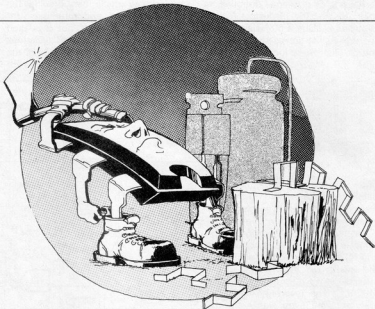


rectangular pulse generator

The excellent properties of counter/divider IC type 4059 have, so far, not been given the prominence in *Elektron* they deserve. One of these properties is the provision of divide ratios anywhere between 3 and 15 999 depending on the logic level at inputs $J_1 \dots J_{16}$ and the setting of switches $S_{17} \dots S_{19}$.

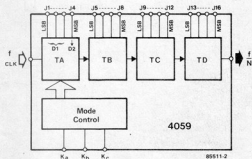
The 4059 is clocked by a relaxation oscillator, N_1-N_2 , which could have been a crystal-controlled type instead of the one shown in figure 1.

The dual-D bistable type 4013 at the output is essential because the width of the pulses at pin 23 of the 4059 is comparable to the clock frequency. The bistable ensures that the pulses emanating from pin 23 are reshaped into rectangular form. The Q output of the bistable is, of course, half the frequency of the wave train at pin 23 of the divider.



Inputs $J_1 \dots J_{16}$ of IC₂ are divided into groups of four. The binary information at these inputs is called $T_A \dots T_D$. Inputs $J_1 \dots J_4$ are further sub-divided into D_1 and D_2 . In total there are, therefore, five data inputs, of which the smallest, D_2 , is only one bit wide. Furthermore, the 4059 has three mode control inputs, $K_a \dots K_c$, whose composition results in a factor K as shown in table 1. If $K=10$, input D_1 becomes four bits wide: J_4 then forms part of

2



D_1 ! The divisor, n , is then calculated from:

$$n = 10^3 T_D + 10^2 T_C + 10 T_B + D_1$$

In all other cases,

$$n = K(10^3 D_2 + 10^2 T_D + 10 T_C + T_B) + D_1$$

The 4059 can be programmed by com-

puter, by hand, or with the aid of an up-or-down counter.

The generator can be used in electrophonics, in measuring techniques, as timer, and even as a digital phase-locked loop frequency synthesizer in

FM tuners.

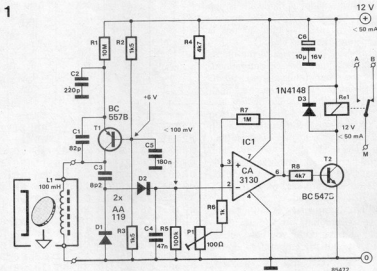
The circuit operates from a 4...15 V supply and current consumption is small.



absorption-type metal detector

The action of the detector, which indicates the presence of ferrous as well as non-ferrous metals, depends on the absorption of magnetic energy. An inductor, which forms part of a tuned oscillator circuit, radiates a magnetic field. When a metal object is introduced into this field, enough magnetic energy is absorbed to cause the oscillator to stop working.

The Colpitt's oscillator in figure 1 operates at a frequency of around 70 kHz. Inductor L_1 also serves as the sensor. Because of the high value of the emitter resistor, R_1 , the oscillator only just operates. This is desirable, otherwise any losses in the tuned circuit would easily be replenished by the transistor. The oscillator output is rectified by D_1 and D_2 , and the resulting direct voltage is applied to the inverting input of Schmitt trigger IC₁. If that voltage drops below the level at



Parts list

Resistors:

- $R_1 = 10\text{ M}$
- $R_2, R_3 = 1\text{ k}$
- $R_4, R_8 = 4\text{ k}$
- $R_5 = 100\text{ k}$
- $R_6 = 1\text{ k}$
- $R_7 = 1\text{ M}$
- $P_1 = 100\ \Omega$ preset potentiometer

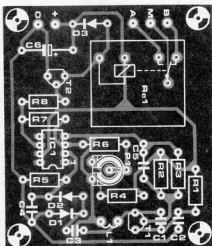
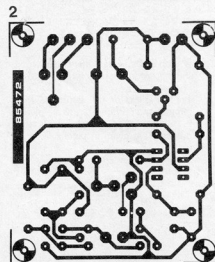
Capacitors:

- $C_1 = 82\text{ p}$
- $C_2 = 220\text{ p}$
- $C_3 = 82\text{ p}$
- $C_4 = 47\text{ n}$
- $C_5 = 180\text{ n}$
- $C_6 = 10\ \mu/16\text{ V}$

Semiconductors:

- $T_1 = \text{BC557B}$
- $T_2 = \text{BC547B}$
- $D_1, D_2 = \text{AA119}$
- $D_3 = \text{1N4148}$
- $IC_1 = \text{CA3130}$

For Components Sources
See Page 9-38



pin 3 (preset by P_1), the output becomes logic high, and the relay is energized.

The detector is best constructed on the printed circuit board shown in figure 2 (this is, unfortunately, not available ready made). Inductor L_1 is not intended to be fitted on the board. This is a standard non-screened choke of 100 mH.

If the oscillator does not readily start at any setting of P_1 , the value of R_1

must be reduced. If, on the other hand, the oscillator does not stop working when a metal object is held near L_1 , the value of R_1 must be increased. The stated value of R_1 has been found right when L_1 is a Toko type.

Starting with the wiper of P_1 to earth, adjust the preset so that the relay just does not operate. If a lower sensitivity is required, advance the wiper slightly further.

Miscellaneous:

- $L_1 =$ choke, 100 mH, non-screened (Toko)
- $Re_1 =$ relay, 12 V, coil resistance not smaller than 240 Ω

Current consumption is determined primarily by whether the relay is energized or not; in any case it is not greater than 50 mA.



morse training with the Junior Computer

J Sgonina

Here is yet another small program to be added to the large amount of software already available for the Junior Computer. It is intended to teach prospective short wave listeners to read morse code. The program can be used even with the basic version of the JC. The only additional hardware is the amplifier stage shown in the accompanying figure. The input to this is taken from port line PB5.

The number and speed of the morse characters can be predetermined. After the program has started, the JC will generate 1 to 6 morse characters, which the trainee should decode and write down. The letters corresponding to the generated characters appear on the display after a short delay, so that the trainee can check his decoding with the actual text. During this phase, the computer is on stand by until an arbitrary key, other than ST and RST, is pressed.

The hex dump given is sufficient to write the program into the JC. Once that has been done, you can prepare the start, but the program needs the following information before it can run.

- in address 0010 write data 00...05;
- in address 0011 write data 01...55 (max);
- in address 0014 write data from table 1 for the first character to be generated minus 1;
- in address 0015 write data from table 1 for the last character to be generated.

Now, the program can be run; it starts in address 0020 when key GO is pressed. Programming example: the JC is to generate morse characters for the letters B to G. Before the start, the following data should be written:

- in address 0010 — data 05
- in address 0011 — data 55
- in address 0014 — data 02
- in address 0015 — data 07

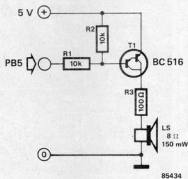
Table 1.

alphanumeric character	hexadecimal code	alphanumeric character	hexadecimal code
A	01	S	13
B	02	T	14
C	03	U	15
D	04	V	16
E	05	W	17
F	06	X	18
G	07	Y	19
H	08	Z	1A
I	09	1	1B
J	0A	2	1C
K	0B	3	1D
L	0C	4	1E
M	0D	5	1F
N	0E	6	20
O	0F	7	21
P	08	8	22
Q	11	9	23
R	12	0	24

Table 2.

address	function
026F	alphanumeric display routine
028D	tone generation routine
02AB	random number routine
02CB	display code table
02EF	morse code table
0000 to 0005	display buffer
0010	number of letters
0011	length of dots and dashes (speed)
0014	lower limit of block of characters to be generated
0015	upper limit of block of characters to be generated

	0	1	2	3	4	5	6	7	8	9	A	B	C	D	E	F
0200:	A9	FF	8D	83	1A	8D	81	1A	85	01	85	02	85	03	85	04
0210:	85	05	18	A5	11	65	11	65	11	85	12	A5	10	AA	20	A8
0220:	02	A8	B9	CB	02	95	00	B9	EF	02	85	21	29	07	85	20
0230:	06	21	B0	07	A5	11	85	13	4C	3F	02	A5	12	85	13	20
0240:	8D	02	C6	20	D0	EA	A5	12	85	13	C6	40	D0	FC	C6	13
0250:	D0	F8	CA	10	C9	20	6F	02	20	AC	1D	F0	F8	20	6F	02
0260:	20	AC	1D	F0	F0	20	6F	02	C6	40	D0	F9	40	00	02	8A
0270:	48	A9	FF	8D	81	1A	8D	83	1A	A2	08	A5	04	20	E3	1D
0280:	CE	7C	02	10	F6	A9	05	8D	7C	02	68	AA	60	A9	FF	8D
0290:	83	1A	EE	82	1A	D0	FB	C6	13	D0	F7	A5	11	85	13	C6
02A0:	4D	D0	FC	C6	13	D0	F8	60	8A	48	38	A5	E9	65	EC	65
02B0:	ED	85	E8	A2	04	B5	E8	95	E9	CA	10	F9	C5	15	B0	EA
02C0:	C5	14	30	E6	85	30	68	AA	A5	30	60	08	03	27	21	06
02D0:	0E	42	09	7A	72	0A	47	48	2B	23	0C	18	2F	52	07	63
02E0:	41	01	36	11	64	79	24	30	19	12	02	78	00	10	40	42
02F0:	84	A4	83	01	24	C3	04	02	74	A3	44	C2	82	E3	64	D4
0300:	43	03	81	23	14	63	94	B4	C4	7D	3D	1D	0D	05	85	C5
0310:	E5	F5	FD													



As soon as these data have been written, the program starts when key GO is pressed.

The hex data for the letters of the alphabet and numbers 0...9 are given in table 1. The most important addresses are given in table 2.

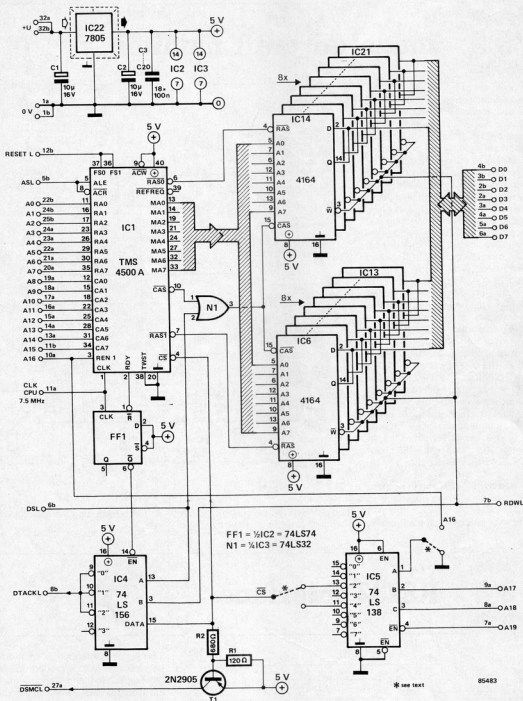


QL RAM extension

Sinclair's QL has as standard a 128 K RAM, which sounds like a lot in comparison with most 64 K machines. Unfortunately, the software writers, in the knowledge that there is more than enough memory, have been rather wasteful in their work, so that at the end of the day, there is not all that

much more in the QL than in the 64 K machines. So, you need more memory... The accompanying circuit is an application of the TMS4500A as RAM extension for the 68008. This chip can drive a maximum of 128 K dynamic RAM and provides virtually

everything: multiplexing of the address lines, RAS, CAS, and REFRESH. The memory ICs are 64 K x 1 (128 or 256 refresh are both permitted) and have a speed of better than 150 ns. Since the QL uses a clock frequency of 7.5 MHz rather than the normal



8 MHz, such a RAM can run without wait cycles. An 8 MHz CPU that regularly has to carry out a wait cycle is appreciably slower than a 7.5 MHz type!

The 68000 family is provided with a data acknowledge input. As with other processors, the CPU places addresses and data onto the bus and indicates the validity with an address strobe and data strobe respectively. It continues to do so until the memory sends a DTACK signal. The present extension generates this signal with the aid of the LS156. Normally, this acknowledgment is given almost immediately, but it may happen that

the 4500 is in the middle of a refresh. In that case, the CPU has to wait, which is arranged via the ready output (pin 2).

To prevent the QL waiting forever when an address is read that has no memory, the DTACK is generated internally: this must, however, be disabled for addresses where the RAM extension is located, and fortunately this can be done easily via DSMC. By making this logic high as quickly as possible, the internal DTACK is cancelled. If you cannot get the 2N2905 transistor, you may use a BS250, in which case resistor R_1 can be omitted and

R_2 should be replaced by a wire link. The circuit as shown is for the 128 K version. It is also possible to omit the eight RAMs connected to RAS1 and make a 64 K extension. Input A of the LS138 must then be connected to A₁₆ and pin 11 instead of pin 13 must be used as CS.

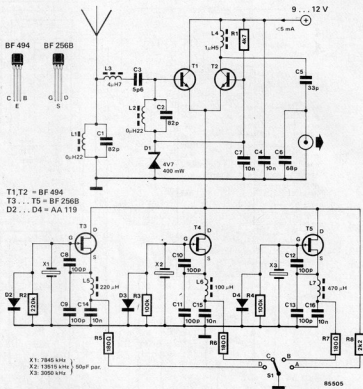
There is no 5 V supply available on the connector, but there is a 9 V line. This can be reduced to 5 V by a standard 7805. The current drawn depends on the types of RAM and will be 200...300 mA. It is important to decouple the supply lines properly: each RAM IC and the 4500 require a 100 nF capacitor!



model aircraft monitor

Older, i.e., not using a computer, radio controlled model aircraft are highly vulnerable to breaks in radio communication, which can lead to a crash or the model landing out of reach, or both. Owing to the allocated radio frequency range being usurped by pirates, it is essential for every model flyer to make sure that the channel to be used is free. Even if it is, it is advisable to continue monitoring it. In combination with a short-wave receiver, the circuit presented here enables monitoring the 27 MHz radio control band. The aerial signal is filtered (26...41 MHz) and applied to the input of differential amplifier T_1 - T_2 . Since the current source of this stage consists of an oscillator, the amplifier functions as a mixer. The crystal oscillator can operate with almost any crystal between 2 and 32 MHz. The output circuit, L_4 - C_5 - C_6 , is tuned to about 27.2 MHz. This frequency is inversely proportional to the values of the coil and capacitors. The values of the crystals are based on a 40-channel set-up. In switch position A, the circuit functions as an aerial amplifier; in position B, channels 38...49 are converted to 8...19; in position C, channels 50...53 are converted to 20...23; and in position D, channels 61...79 are converted to 21...39.

The receiver into which the monitor is

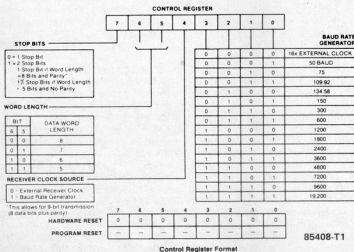


coupled need not be suitable for FM reception: an AM receiver can work

on FM by detuning the monitor a few kHz.

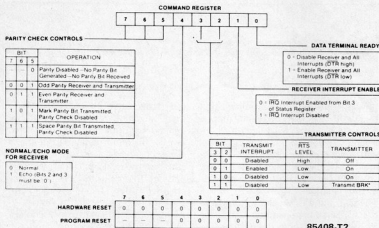


RS232 interface



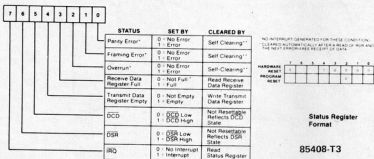
This circuit is intended as an interface between the Elektor modem (Elektor, November 1984) and a computer. The software for each individual computer must, of course, be written separately. Since the writing of a terminal program can only be carried out in machine language, the interface can be kept quite simple.

Signals at TTL level are sufficient to operate the modem and LS05 buffers are therefore used. Complete address decoding of the 6551 is ensured by IC_2 and IC_3 so that only four locations in the memory are required, and these should be available on virtually any computer. The fourteen common address bits are selected with S_1 ... S_{14} ; a closed switch represents an address bit or 0. The input buffers are standard RS232 line receivers so that they can cope with any voltage



85408-T2

Command Register Format



Status Register Format

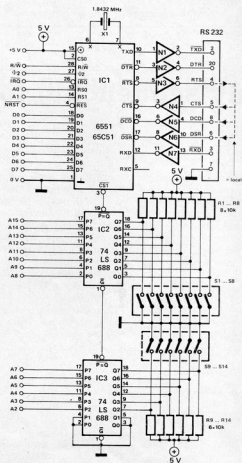
85408-T3

Register Select Coding

RS1	RS0	Write	Read
0	0	Transmit Data Register	Receiver Data Register
0	1	Programmed Reset (Data is "Don't Care")	Status Register
1	0	Command Register	
1	1	Control Register	

Note that only the Command and Control Registers can be accessed during both Read and Write operations. Programmed Reset operation does not cause data transfer, but is used to clear (reset) all 6855C51 internal registers. Programmed Reset is used in a slightly different way as compared to the hardware Reset (RES). These differences are described under each individual register description.

85408-T4





VLF converter

Strictly speaking, the VLF (very low frequency) band stretches from 3 kHz to 30 kHz, and the LF (low frequency) band, often called the long-waveband, from 30 kHz to 300 kHz. The converter described here covers the frequency range 10...150 kHz and falls, therefore, half-way between being a VLF and an LF converter.

Frequencies between 10 kHz and 150 kHz are converted to 4.01...4.15 MHz which can be fed to any short-wave receiver capable of accepting those frequencies. The converter is connected to the aerial input of the receiver via coaxial cable.

Many converters suffer from breakthrough of the mixer/oscillator frequency in the output signal, which is normally caused by the mixer being asymmetrical. Because of that, the present converter uses the well-known S042P frequency changer, the symmetry of which can be set accurately with a 1 k preset potentiometer connected between pins 10 and 12.

To prevent reception of image frequencies, the aerial signal is first applied to an LC band-pass filter, before it is fed to the frequency changer.

The output of the frequency changer

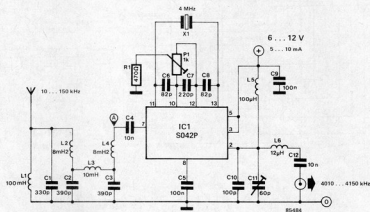
(pin 2) is applied to an LC circuit that is tuned to the frequency range 4.01...4.15 MHz. This circuit, consisting of a 100 μ H inductor in parallel with a 100 nF capacitor and a 60 pF trimmer, effectively suppresses any spurious signals produced in the frequency changer.

The 60 pF trimmer is used to tune in to the desired transmitter in the 10...150 kHz range (loudest reception!). The symmetry of the frequency changer is set by tuning the short-wave receiver to the frequency of the

quartz oscillator, i.e., 4.00 MHz, and then adjusting the 1 k preset for minimum output from the converter, that is, minimum deflection of the S meter, or other field strength indicator, on the receiver. During this calibration, the input of the frequency changer, point A in the diagram, should be short-circuited to earth.

All inductors are standard RF chokes. The value of the output inductor, 12 μ H, is not critical.

The aerial should be as long a wire as possible.



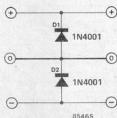
power supply sequencing for opamps

Most designers know that many problems may arise between the paper design and the practical realization of that design. We are, of course, no exception, and one incident that we experienced recently illustrates a problem that is of interest to pass on.

Measurements were being carried out on a circuit that contained some type NE 5532 opamps which were powered from a ± 12 V symmetrical supply. When the circuit was switched on, it did not function correctly. Measuring the supply lines revealed that the positive supply was -0.6 V instead of $+12$ V. When the $+12$ V line only was switched off and immediately on again, the malfunction disappeared. Switching off the mains and immediately on again made the defect reappear. Using new opamps made no difference.

After some research in relevant literature, it appeared that on

switching symmetrical power supplies temporary polarity reversal may occur. Because of the complex internal structure of integrated circuits, it may happen that this polarity reversal causes parasitic components on the chip to be actuated which places the IC in a stable but malfunctioning state.



The book we consulted, *Intuitive IC Opamps*, suggests that the malfunction we experienced was probably caused by a parasitic thyristor being triggered owing to the negative supply not rising fast enough. The remedy proposed was to connect two diodes across the supply lines as shown in the accompanying figure: these diodes effectively prevent polarity reversal.

This simple remedy certainly cured the malfunction in our circuit and is probably the simplest protection circuit in this issue.

Literature:
Intuitive IC Opamps
by Thomas M Frederiksen
National Semiconductor Corporation



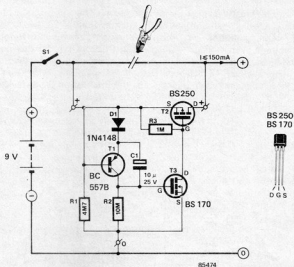
automatic switch off

If you are one of the many who frequently forget to switch off their digital multimeter, this circuit is for you.

When this little circuit, which is intended to be incorporated in the multimeter, is switched on, capacitor C_1 is connected to the +9 V line via D_1 . Since C_1 is discharged, the gate of T_3 is also at +9 V which causes T_3 and T_2 to conduct. The meter is then switched on.

Capacitor C_1 slowly charges via R_2 . After about 2 or 3 minutes, the potential at the gate of T_3 becomes too low to keep the FET in conduction. Transistor T_2 then also switches off, and the battery is disconnected from the multimeter.

Transistor T_1 ensures that when the multimeter is switched off manually, capacitor C_1 is discharged. When the multimeter on/off switch, S_1 , is opened, a base current will flow to the negative terminal of C_1 via R_1 and R_2 . Transistor T_1 then conducts and discharges C_1 . The circuit is thus immediately ready for use again. Without T_1 , there would have to be a delay of a few minutes before the circuit could be switched on again.



The circuit is best built on a small piece of vero board and then fitted between the on/off switch and the meter itself.

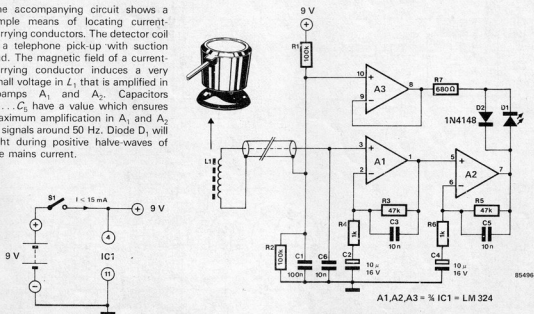
A final tip: T_2 could be replaced by a Darlington, such as a BC516, in which case a 1 MΩ resistor would have to be inserted in the connection to the drain

of T_3 . This arrangement would have the advantage that the BC516 is more easily obtainable than the BS250, but the disadvantage of causing a slightly larger voltage drop across the circuit: 0.8 V as compared with less than 0.1 V when a BS250 is used. The current in both cases is 10 mA.



mains wiring locator

The accompanying circuit shows a simple means of locating current-carrying conductors. The detector coil is a telephone pick-up with suction pad. The magnetic field of a current-carrying conductor induces a very small voltage in L_1 that is amplified in opamps A_1 and A_2 . Capacitors $C_2 \dots C_5$ have a value which ensures maximum amplification in A_1 and A_2 of signals around 50 Hz. Diode D_1 will light during positive half-waves of the mains current.



A1, A2, A3 = $\frac{1}{2}$ IC1 = LM 324



direct reading digitizer

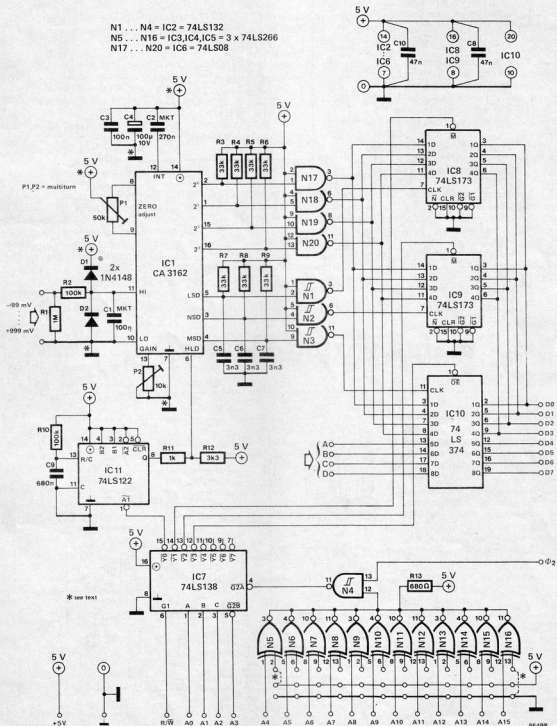
The computer to which this digitizer is coupled reads a 3-digit number that is a direct representation of the measured voltage in millivolts.

The analogue-to-digital converter is an RCA type CA3162, which was designed for use in a 3-digit digital

voltmeter. The input range of the IC stretches from -99 mV to 999 mV ; the resolving power is, therefore, 1098 units. In other words, this converter offers a resolving power that is better than that of a standard 10-bit device for the price of an 8-bit device.

The 3-digit information at the output of the 3162 is multiplexed. The data can, for instance, be written into the micro via seven PIA (peripheral interface adapter) input lines. That means, however, that some machine language is required to be loaded into

- N1 ... N4 = IC2 = 74LS132
 N5 ... N16 = IC3, IC4, IC5 = 3 x 74LS266
 N17 ... N20 = IC6 = 74LS08



the RAM every time the converter is to be used. The present circuit uses hardware to obviate this difficulty. The 3-digit information, which is emitted every 20 ms, is automatically loaded into three 4-bit buffers, IC₃, IC₉, and 1/2 IC₁₀, whose outputs are connected direct to the data bus. Each of these buffers has its own address. Writing the converted value into the computer has become simply a matter of reading the three memory locations, which can be carried out by PEEKs in BASIC.

The address decoder consists of IC₃, IC₉ and IC₁₀.

The present circuit occupies a block of eight addresses of which only the first four are used. When the first address is read, monostable IC₁₁ is started, which causes IC₁ to commence the conversion process. When the monostable returns to its stable state, IC₁ goes to the HOLD mode, and the measured voltage can be read. An interval of not less than 50 ms is required between the start of the conversion process and the reading of the buffers.

The eight successive memory locations required for the digitizer may be placed anywhere in the memory range by means of the open inputs of gates N₆...N₁₀. If any of these inputs is connected to +5 V, the relevant address line becomes logic 1; if the input is linked to 0 V, the address line goes logic low.

Assuming that the decoding has been set to address \$E300, the first address is read with a PEEK, which starts the conversion.

Wait for 50 ms.

Write the data from address \$E301, which is the least significant bit (LSB), i.e., the extreme right-hand digit of the 3-digit number. Then write \$E302 and finally \$E303. At each of these transfers, an AND action must be carried out with 00001111 (binary) or 15 (decimal), because only the four lowest data bits are of import.

If the converted voltage during the further processing of the three written digits is negative, this is indicated by the data at address \$E303, which is 10.

Overflow is also easily recognized: if the value read from address \$E301 is 11, the voltage is greater than 999 mV; if the value is 10, there is a negative overflow.

The small BASIC program given here is an example of a possible conversion routine for the Junior computer.

The circuit as shown can be used with a 6502 μ P; if it is required to be used

with a Z80, RD must be connected to the R/W line via an inverter, and IORQ or MREQ is put onto the 02 line via an inverter. The choice between IORQ and MREQ depends on whether the digitizer is located in the I/O or the memory range respectively.

Take care during the construction to keep the connections marked with an asterisk (0 V and +5 V to IC₁) as short as possible. These lines go together to C₃ and C₄, from where the connection is made to the 0 V and +5 V lines of the digital part of the circuit. Keeping these lines short prevents possible interaction between the analogue and digital parts of the circuit.

Four inputs of IC₃ are not used in the present circuit, and they can, therefore, serve as four additional digital inputs. During the reading of address \$E303 (in the example), the highest four data bits indicate the state of these four inputs.

```

10 A=14X16^3+3X16^2: REM ADDRESS $E300
20 B=PEEK(A): REM START CONVERSION
30 FOR T=1 TO 15: NEXT: REM DELAY
40 X=PEEK(A+1) AND 15
50 Y=PEEK(A+2) AND 15
60 Z=PEEK(A+3) AND 15
70 S=1
80 IF Z=10 THEN Z=0: S=-S: REM SIGN IS NEGATIV IF Z=10
90 AD=SX(100XZ+10XY+X)
100 IF X=11 THEN PRINT " POS.OVERFLOW "; CHR$(13);: GOTO 130
110 IF X=10 THEN PRINT " NEG.OVERFLOW "; CHR$(13);: GOTO 130
120 PRINT " U=";AD;" mV "; CHR$(13);
130 GOTO 10

```



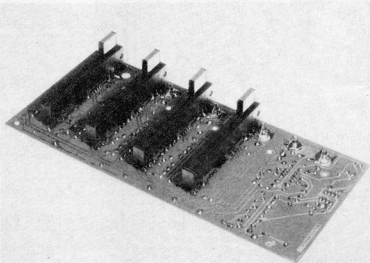
discomixer

This mixer is a typical example of the way modern components can, and do, simplify the realization of good quality audio circuits. In the given configuration it is eminently suitable for use as a discomixer, but the number of input channels can easily be enlarged.

As can be seen in figure 1, in its basic form the mixer has four input channels. These could, for instance, serve as inputs for a microphone, stereo pick-up, and cassette player or tape recorder.

The power supply has been kept as simple as possible; if it proves difficult to obtain the XR4195 regulator IC, it may be replaced by a combination of a 78L15 and 79L15. The transformer is preferably of the PCB type to keep the mixer as compact as possible.

The values of C₁ and R₁ are dependent on the type of microphone used.



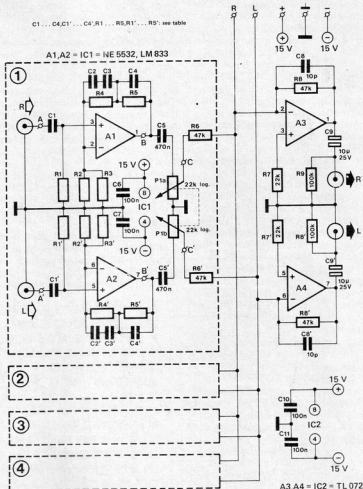
If this is a high-impedance type, the values should be 470 nF and 22 k Ω respectively, whereas with low-impedance types, 10 μ F and 680 Ω are required.

Unfortunately, miniature bipolar electrolytic capacitors (C_1 , C_1' , C_9 , and C_9') are not yet available everywhere, although they are almost indispensable in applications such as described here. Standard electrolytics may be used with maximum reverse voltages of 1 V, but their use introduces distortion and premature ageing (because of the reverse polarity).

Provision has been made on the printed circuit board for up to four channels. Two or more PCBs may be connected together; the output and supply sections may then be cut off as required.

Current consumption is about 10 mA per channel.

1



2

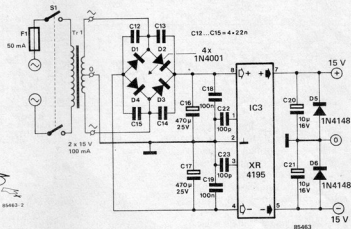
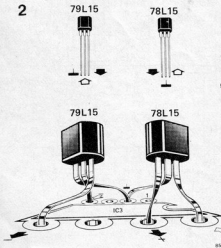


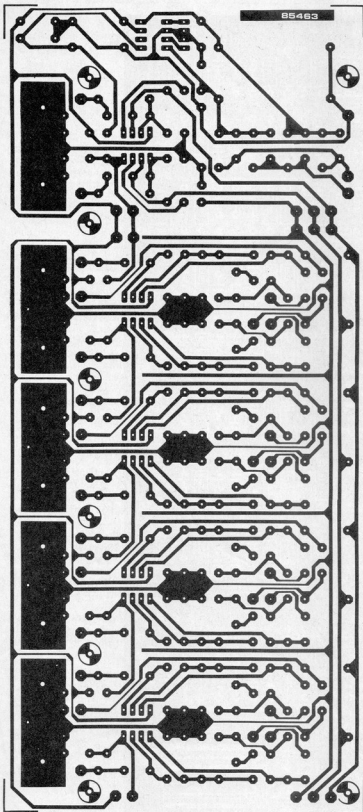
Table 1.

	C_1	C_2	C_3	C_4	R_1	R_2	R_3	R_4	R_5	
pick-up	220 n	1n5	1n5	3n3	47 k	2k2	2k2	100 k	1 M	
tape/cassette	***	***	***	***	***	***	***	***	***	see Note 1
microphone (high impedance)	470 n	***	***	10 p	22 k	1 k	***	o-o	100 k	see Note 2
microphone (low impedance)	10 μ /25 V	***	***	10 p	680 Ω	1 k	***	o-o	100 k	see Note 2

o-o = wire link
*** = not required

Note 1. Wire links A-B and A'-B' required; IC₁, C₉, and C₇ not required.

Note 2. With mono microphones, use input R; do not connect P₁₅; wire link C-C' required; all accented components not required.



Parts list

Resistors:

$R_1^* \dots R_5^*, R_1^* \dots R_5^*$ = see table
 $R_6^*, R_6^*, R_6^*, R_6^*$ = 47 k
 R_7^*, R_7^* = 22 k
 R_8^*, R_8^* = 100 k
 P_{1a}^*, P_{1b}^* = 22 k stereo slide potentiometer, log, 58 mm long

Capacitors:

$C_1^* \dots C_4^*, C_1^* \dots C_4^*$ = see table
 C_5^*, C_5^* = 470 n
 $C_6^*, C_7^*, C_{10}, C_{11}, C_{18}, C_{19}$ = 100 n
 C_8, C_8 = 10 p
 C_9, C_9 = 10 μ /25 V
 $C_{12}, C_{13}, C_{14}, C_{15}$ = 22 n
 C_{16}, C_{17} = 470 μ /25 V
 C_{20}, C_{21} = 10 μ /16 V
 C_{22}, C_{23} = 100 p

Semiconductors:

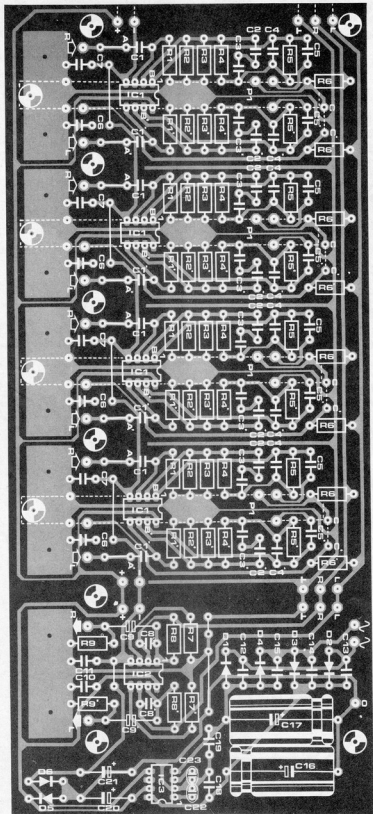
$D_1 \dots D_4$ = 1N4001
 D_5, D_6 = 1N4148
 IC_1^* = NE5532 or LM833
 IC_2 = TL072
 IC_3 = XR4195

Miscellaneous:

Tr_1 = mains transformer, secondary
 $2 \times 15V/100$ mA
 F_1 = fuse, 50 mA, delayed action
 S_1 = DPST on/off switch
 Single-hole fixing chassis phono socket —
 2 per channel

*One of each required per channel.

For Components Sources
 See Page 9-3B





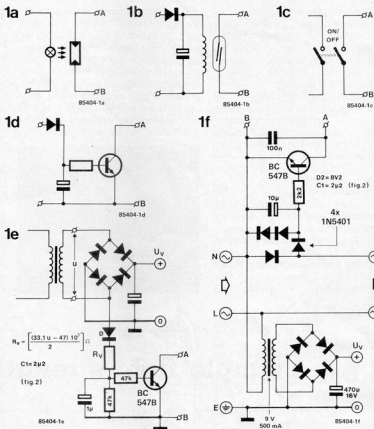
loudspeaker protection

There are many ways of protecting loudspeakers against the switch-on 'plop': many of these rely on a clamp circuit across the power amplifier input to hold this at 0 V for a few seconds after switch-on. Others, like the one suggested here, depend on a relay to switch off the loudspeaker(s). Terminals A and B of the circuit in figure 2 are connected to one of the sensing circuits in figures 1a...1f, of which the pros and cons will be discussed shortly. Whichever of these circuits is used, A is shorted to B immediately the power is switched on. This cuts off transistor T1 instantly, which causes capacitor C1 to charge. After a few seconds, the voltage across C1 causes zener D2 to break down. Transistor T2 and T3 then conduct; and relay is energized, and the loudspeakers are connected in circuit. When the power is switched off, T1 conducts and this causes C1 to discharge very rapidly. The voltage across C1 quickly drops below the breakdown level of D2; transistors T2 and T3 are cut off, and the relay returns to its quiescent state, which disconnects the loudspeakers. Input circuit 1a relies on a light-dependent resistor (LDR) fitted close to the mains on indicator lamp. When the lamp lights, the resistance of the LDR drops sharply, so that terminal A is virtually shorted to B.

The input in 1b relies on a reed relay connected to the secondary winding of the mains transformer. As soon as the mains is switched on, the relay contacts close.

The third possibility, shown in 1c, is that the mains on/off switch has a third contact that connects A to B when the mains is switched on.

A further option is illustrated in 1d,



where a transistor is connected to the secondary of the mains transformer via a diode and resistor. The transistor conducts when the mains is switched on.

The inputs in 1e and 1f also provide power for the protection circuit. That in 1e has a bridge rectifier connected across the secondary winding of the mains transformer. When the mains is

switched on, the BC 547 conducts and shorts A to B.

Finally, the circuit in 1f is connected direct to the mains. Here again, as soon as the mains is switched on, the BC 547 conducts and terminal A is shorted to B.

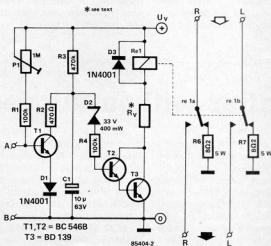
Whichever of the input circuits is used depends on circumstances and/or individual preferences. If one of circuits 1a...1d is used, a separate power supply is required for the protection circuit. As suggested, the output voltage, U_v , of this should be 40...60 V d.c. For lower values of U_v , the rating of D2 must be reduced accordingly.

Resistance R_v depends on the relay used, and is calculated from $R_v = [(U_v - U_i) - 2.5] / I_r$ Ω where U_i and I_r are the operating voltage (in volts) and current (in amperes) of the relay used respectively.

The relay contacts must be able to carry a large current: 10 A is not unusual in many amplifiers.

The rating of R_v is $[U_v] W$. If the 'plop' is still heard, increase the value of R3 as required — in reasonably small steps.

2





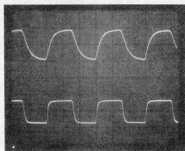
fast opto-coupler

The opto-coupler in the normal common emitter circuit at the output of a phototransistor is invariably too slow for use in data communication. Its great advantage remains, of course, the excellent isolation between transmitter and receiver.

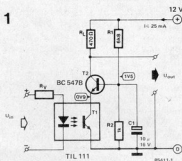
To retain the advantage, the phototransistor has been integrated into a cascode circuit, as shown in figure 1. The photograph illustrates data transfer in a conventional circuit (top) and in the cascode circuit — the fast opto-coupler — (bottom) at a frequency of about 30 kHz.

The cascode circuit's faster operation is due to the transistor's internal Miller capacitance being of no consequence as the collector voltage remains constant. The result is a faster transistor. The base of T_2 is biased at about 1.5 V by voltage divider R_1/R_2 . Capacitor C_1 ensures that, even with rapid fluctuations in current, this

voltage remains stable. If you consider T_2 as an emitter follower, it is clear that the collector of T_1 is always provided with a constant (direct) voltage, and this causes the Miller (base-to-collector) capacitance to be inactive. A disadvantage of the fast opto-coupler is that its output signal does not go down to 0 V but at best to 1 V. TTL devices like this just as little as they do a supply voltage of 12 V.



1



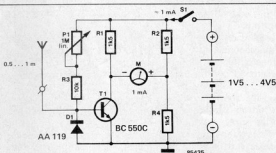
Basically, the circuit can operate from 5 V, provided R_1 is altered suitably, but it is better to use CMOS devices. Take care during experimenting not to exceed the maximum LED current (in the TIL 111) of 100 mA (this is the reason for dropping resistor R_3). The value of R_1 is calculated from $R_1 = (U_m - 1.5) / I_{LED}$ where U_m is in volts and I_{LED} in amperes.



simple field strength indicator

A practically proven small circuit that is very popular with many model fliers, is that it enables them to verify that their remote control transmitter is actually transmitting. Any doubt as to whether a fault lies in the receiver or transmitter is also quickly resolved.

The only active element in the circuit is a transistor that is used as a controlled resistance in one of the arms of a metering bridge. The base of the transistor is connected to the wire or rod aerial. The increasing HF voltage at the base of the aerial drives the transistor so that the bridge is brought



out of equilibrium. A current then flows through R_2 , the mA meter, and the collector-emitter junction of the

transistor. The meter should be zeroed with P_1 before the transmitter is switched on.



active rectifier without diodes

The active rectifier proposed here is based on the property of an operational amplifier that its output cannot become negative if its power supply is asymmetrical. We have used an RCA type CA 3130 opamp which is eminently suitable, because it can cope with input voltages down to 0 V, and has a CMOS output stage that

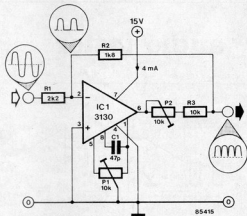
can also work down to 0 V. With a supply voltage of 15 V, the maximum input level is about 1.2 V_{max} . The frequency range, for not more than 1 dB change in output, extends from DC to just over 25 kHz. Negative half cycles at the input of the opamp are inverted and amplified by a factor R_2/R_1 . Positive half cycles are

also inverted, but, as stated, the output of the opamp cannot become negative, and it therefore remains at 0 V. The positive half cycles are also applied to the output of the opamp via a resistive divider, $R_1/R_2-R_3/P_2$. The result of all this is that only positive half cycles are present at the output, just as if full-wave rectification had

taken place. If the asymmetry of the supply is set correctly with P_2 , the peak values of the inverted negative half cycles and the positive half cycles are equal.

Preset P_1 should be adjusted to give zero output when the input of the opamp is connected to earth.

The rectifier has a low-impedance input (source impedance should be not greater than 100 Ω) and a high-impedance output (load impedance should be not less than 1 M Ω). If these requirements as to source and load impedance cannot be met, the values of R_1 and/or R_3 should be modified: R_1 + source impedance should be about 2k Ω , while the parallel combination of R_3 and the load must be around 10 k Ω .



floppy disk drive

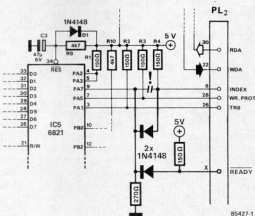
This is a much simplified version of the circuit published in the May 1984 issue of *Elektor*, but it is, unfortunately, not usable with all disk drive motors.

First, a recap of the operation. The drive motors are switched on when one of the drives is accessed by a DISK SELECT signal. There is a delay of a few index pulses before access proper to give the motor speed time to stabilize. A few seconds after all the drives have been deselected, the motor is switched off. This arrangement reduces operation of the drive mechanisms, the heads, and the disks to a minimum, which ensures a longer life of these devices.

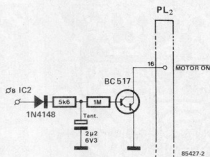
In contrast to the earlier published article, the READY output of the drive mechanism is used, wherein lies the reason that the older circuit cannot be as compact and simple as the present one: it has to take into consideration that not all drive mechanisms have this output. However, as far as we can find out, most drive mechanisms do have it, but there must be some, of course, that do not.

Figure 1, which is part of the circuit of the floppy controller board (*Elektor (UK)*, November 1982), shows the new wiring of port A_7 . The x at plug PL_2 represents pin 3 of the type FD-55x drive mechanism, and pin 6 of the BASF 6106. As this latter input corresponds to Disk Select 4, not more than three BASF 6106 drives can be connected to the present circuit. It is a wise precaution to break the connection between pin 10 of gate N_{25} and pin 6 of PL_2 , but it is not strictly necessary. As long as you do not select drive 4 (with the Ohio DOS, drive D), nothing can go wrong.

1



2



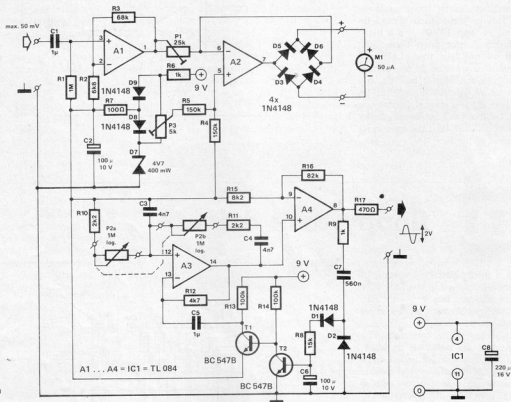
One connection that must be broken is that between pin 16 of PL_2 and earth. Instead, pin 16 must be connected to pin 8 of IC_2 as shown in figure 2.

If you are really a dab hand at soldering, you may be able to make the changes, with the appropriate

lengths of wire, on the relevant printed circuit board. Most of you will, however, find it much easier to use a 15x20 mm piece of veroboard, which after completion can be glued or screwed on short spacers underneath C_{16} on the floppy controller board.

audio tester

1



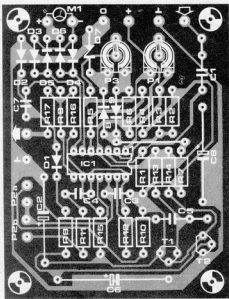
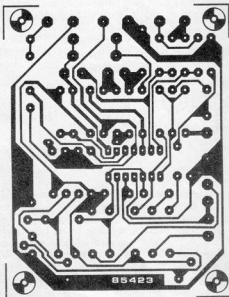
A simple millivoltmeter and an equally simple sine wave generator are ideal instruments for checking and testing audio equipment. The audio tester combines the two, as shown in figure 1, where A_1 and A_2 form the millivoltmeter circuit, while the sine wave generator is built from A_3 and A_4 .

As the audio tester is supplied (asymmetrically) from a 9 V battery, this supply must be halved for the operational amplifiers. This is essentially done by zener diode D_7 . This zener is biased by R_6 , and the reference voltage is taken from the junction of diodes D_8 and D_9 via resistor R_7 . The reference voltage is, therefore, about

5.3 V. The constant voltage drop across the two diodes is applied across preset P_3 which serves to negate the offset voltage of A_2 (enabling the millivoltmeter to be calibrated to zero).

The input signal is applied across high pass filter C_1/R_1 to the non-inverting input of A_1 . For all practical purposes,

2



Parts list

Resistors:

$R_1 = 1 \text{ M}$
 $R_2 = 6\text{k}8$
 $R_3 = 68 \text{ k}$
 $R_4, R_5 = 150 \text{ k}$
 $R_6, R_9 = 1 \text{ k}$
 $R_7 = 100$
 $R_8 = 15 \text{ k}$
 $R_{10}, R_{11} = 2\text{k}2$
 $R_{12} = 4\text{k}7$
 $R_{13}, R_{14} = 100 \text{ k}$
 $R_{15} = 8\text{k}2$
 $R_{16} = 82 \text{ k}$
 $R_{17} = 470 \Omega$
 $P_1 = 25 \text{ k}$ preset (see text)
 $P_2 = 1 \text{ M}$ stereo preset, log.
 $P_3 = 5 \text{ k}$ preset

Capacitors:

$C_1, C_2 = 1 \mu$ metallized plastic foil
 $C_2, C_6 = 100 \mu\text{F}/10 \text{ V}$
 $C_3, C_4 = 4\text{n}7$
 $C_7 = 560 \text{ n}$
 $C_8 = 220 \mu\text{F}/16 \text{ V}$

Semiconductors:

$D_1 \dots D_6, D_8, D_9 = 1\text{N}4148$
 $D_7 = \text{zener diode } 4\text{V}7/0,4 \text{ W}$
 $T_1, T_2 = \text{BC } 547\text{B}$
 $IC_1 = \text{TL}084$

Miscellaneous:

$M1 = \text{moving coil meter, } 50 \mu\text{A}$ (see text)
 PP3 (9 V) battery with dual miniature clip
 $\text{SPST on/off switch}$ (optional - see text)

For Components Sources
See Page 9-38

this sets the input impedance at $1 \text{ M}\Omega$. Note that the circuit is fully driven with an input signal of $50 \text{ mV}_{\text{rms}}$. Higher inputs necessitate a voltage divider at the input or a reduction in gain in A_1 by dropping the value of R_3 . When this resistor is reduced to $6\text{k}8$, for instance, the gain of A_1 is 2, and the input sensitivity is $275 \text{ mV}_{\text{rms}}$.

Full-scale deflection of the meter is set by P_1 . Opamp A, together with diodes $D_3 \dots D_6$, functions as an active full-wave rectifier. The meter is connected in of the diagonals of the diode bridge. To ensure that even small AC voltages can be measured, the potentials at both inputs of A_2

must be absolutely equal. Because of this, a small offset voltage is applied to the non-inverting input via R_6 .

The sine wave generator is essentially a Wien bridge oscillator, A_2 , whose frequency determining components are P_2, C_3 , and C_4 . To ensure stable operation, an active feedback loop takes part of the output signal of buffer amplifier A_4 , rectifies this (D_1, D_2) and applies the consequent DC voltage to the inverting input of A_3 via buffer stages T_1 and T_2 . The output voltage of the generator section is 2 V_{pp} .

The audio tester is best constructed on the printed circuit board of figure 2. The meter can be almost any type from $50 \mu\text{A}$ to 1 mA . Note, how-

ever, that the value of P_1 in figure 1 applies to a $50 \mu\text{A}$ instrument; for a different f.s.d., this value can be changed inversely proportional. For instance, if the instrument is a $500 \mu\text{A}$ type, P_1 should be $2\text{k}5$.

The millivoltmeter is calibrated by tapping the reference voltage with a divider of 820Ω in series with $100 \text{ k}\Omega$: the voltage at their junction will be 45 mV . Apply that voltage to the non-inverting (+) input of A_1 , and adjust P_1 till the meter reads "45".

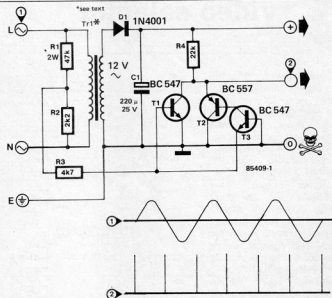
The current consumption of the audio tester is some 10 mA , and it is therefore advisable to incorporate an on/off switch. The frequency range extends from 150 Hz to 20 kHz .



simple zero crossing detector

Zero crossing detectors are often contained in rather complex circuits, or they are part of an integrated circuit, the rest of which is not required. Basically, such a detector is required to give a pulse every time the mains voltage passes through the zero potential.

The detector proposed here is very simple indeed: the mains voltage is transformed down, rectified in D_1 , and smoothed by C_1 to give a direct voltage of 17 V . Part of the mains voltage is taken from across R_2 and used to drive transistors $T_1 \dots T_3$. During positive half cycles T_1 conducts and T_2 and T_3 are off, whereas negative half cycles switch on T_2 and T_3 , while T_1 is off. When the momentary voltage across R_2 lies between $+0.6 \text{ V}$ and -0.6 V , none of the transistors conducts, so that the output voltage is high. In this way, a short positive pulse is produced every time the mains voltage passes through zero potential. Since operation is direct from the mains, there is no phase shift caused by the usual isolating transformer.



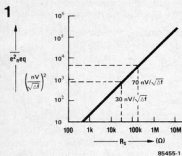
Where the direct voltage output of the circuit is used for supplying external circuits, attention should be paid to the current required by those circuits and the rating of the transformer. It

may also be necessary to increase the value of C_1 .

Finally, remember that the circuit and, therefore, any external units are connected direct to the mains!

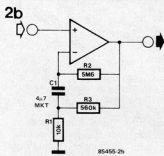
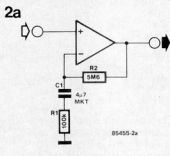


designing a low noise amplifier



To design a low noise amplifier, it does not suffice to choose a low noise opamp, because the components associated with the opamp, particularly resistors, are themselves sources of noise. The noise in a resistor, which is caused by random movement of electrons, increases by the square root of the increase in resistance.

Figure 1 shows a very convenient characteristic for determining optimum values of input resistance. The y-axis gives the square of the sum total of noise voltage produced in a circuit (in nV over the bandwidth considered), while the x-axis gives the value of the source resistance.



For instance, a noisy opamp like the 741, which produces some 70 nV of noise over its bandwidth, can cope with an input impedance of some 200 k (higher values would cause the input impedance to generate more noise than the opamp!). On the other hand, the less noisy TCA 520, which generates about 30 nV of noise over its bandwidth, should have an input impedance not greater than about 50 k.

It is not always convenient to use such relatively low values of resistance. For example, the audio amplifier in figure 2a is intended to operate down to 0.3 Hz; because of that, the time constant, $\tau = RC$, must be fairly long.

The input (= source) impedance of the opamp is determined primarily by R_1 . Lower values of this resistor would require a higher value of C_1 and this is not acceptable on cost grounds. The solution to this problem is shown in figure 2b, where both the DC and AC amplification are the same as in 1a, but because R_1 is 10 times as small, its noise voltage is reduced by $\sqrt{10}$.

Sources

Figure 1: *intuitive IC opamps* (T M Frederiksen — National Semiconductor)

Figure 2: *technical note 068* (Philips)



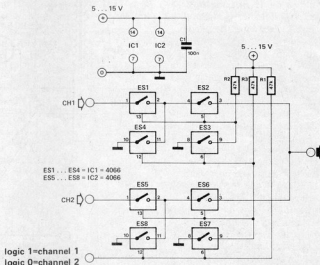
video selector

It is sometimes useful, or even necessary, to use the same screen for more than one video source. Some simple video selectors used for this purpose suffer rather badly from crosstalk. The present circuit does not have this drawback: the unused channel(s) is shorted out with a switch.

When CH(annel) 1 is switched in, electronic switches ES_1 and ES_2 are closed and ES_4 is open. The other channel(s) is effectively choked because ES_5 and ES_6 are both open and any residual crosstalk is shorted to earth by ES_7 . Each channel uses its own IC so that there is no risk of cross channel interference via the chips.

As the switches have a certain impedance in the on state, there will be some losses when the output is terminated into 75 Ω . It is, therefore, best to buffer the output; for instance, with the *video buffer/repeater* described elsewhere in this issue.

The input of the video selector must be terminated into 75 Ω . The -3 dB



bandwidth is about 8 MHz. Current consumption amounts to 1...2 mA depending on the supply voltage. A high supply voltage is preferable,

because the electronic switches then have the lowest impedance in the on state.

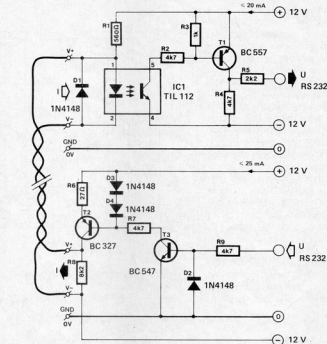


current loop for modem

A modem, such as the *direct-coupled modem* featured in the November 1984 issue of *Elektron*, opens a whole new world to the computer user by making possible communication between two computers anywhere in the world (provided, of course, they can be coupled to a telephone line!). Ironically, although the distance between the computers may be very large, that between computer and modem is strictly limited. This is because the RS 232 input is voltage driven and is, therefore, very susceptible to noise. This is not a new problem: it existed many years ago when, for instance, two telex machines had to be interconnected. The solution then found, and still in use today, is the current loop. Such a current loop can also be used when the distance between the modem and the computer is relatively large: up to 1 km.

A current loop so used converts RS 232 compatible voltages into RS 232 compatible currents. The standard in the RS 232 protocol is a current loop of 20 mA.

In view of the arrangement of the circuit it is possible for the current loop to be used as a voltage driven input and output. In the receiver, the optoisolator converts the input current into an output voltage via T_1 . The output voltage is ± 12 V. As the current loop is closed via V^+ and V^- , mind the polarity. If you want to use an input



voltage instead of a current, apply the input between V^- and earth.

The input voltage to the transmitter may vary from TTL level to ± 12 V. Its output signal is available as either a voltage or a current: the former between V^+ and earth and the latter between V^+ and V^- .

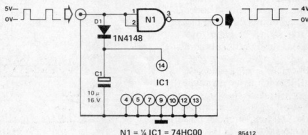
Current consumption in the quiescent state is zero; with full load, it amounts to 20 mA.

The maximum bit rate at which the circuit operates reliably is 1200 baud, but this can be increased by the use of a faster optoisolator.



sync inverter for the QL

For some unknown reason, the Sinclair QL (and perhaps some other personal computers) provides positive, instead of the usual negative, field synchronizing pulses to the monitor. Inverting these pulses with a suitably fast NAND gate or inverter is, of course, no problem. What is a problem is where to power this gate from: a special supply would be nonsense. However, in the circuit proposed here, the gate is supplied from the sync signal itself. A monitor with TTL input for the sync signal draws only a very small current at logic 1, so that the additional load presented to the input pulse by the diode and electrolytic capacitor is inconsequential. Instead of the HC-MOS gate shown, it is also possible to use a buffered



CMOS gate, for instance, a type HEF4011B. Standard CMOS devices, such as the 4011, cause a very small delay, which in practice does not matter, and certainly not with a field sync

signal. Note that it is important, as always with CMOS devices, to connect unused pins to earth (pin 7) or to V_b (pin 14).

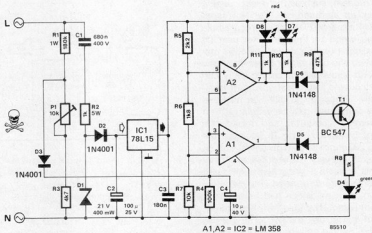


mains voltage monitor

It is often desirable to know at a glance whether the mains voltage is at the low side; for instance, when you are about to work on a computer program. The danger is, of course, that when it is already low, further loads may cause the mains to drop below an acceptable level.

The supply for the present circuit is taken direct from the mains, which exists across R_1 and P_1 . The 15 V stabilized voltage produced by R_2 , C_1 , C_2 , D_1 , and D_2 provides two reference voltages. These voltages are compared in A_1 and A_2 with a fixed proportion of the mains. If the mains is below 210 V, D_7 lights, and when it is higher than 250 V, D_8 lights.

When neither D_7 nor D_8 lights, T_1 switches on and causes D_4 to light, indicating that the mains voltage is within acceptable limits. The mains voltage limits are set with P_1 , with the aid of a multimeter and a variac; where perfectionism is not required,



the preset may be set to roughly the centre of its travel. Remember that this circuit is not

isolated from the mains and it must, therefore, be housed in a man-made fibre case.



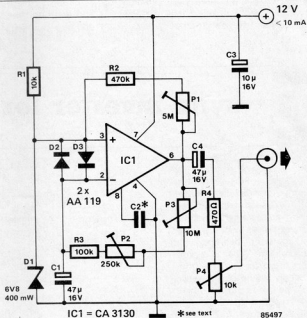
noise generator

Noise is normally defined as unwanted electrical signals spread over a relatively flat, wide frequency spectrum. In most equipment, great care is taken to reduce the amount of noise to a minimum, resulting in a low noise factor.

None the less, noise is useful for measuring the behaviour of a circuit under varying input conditions. A noise generator is used, for instance, for measurements on coaxial cables, microwave links, and RTTY (radio teletype) and CW (continuous wave=radio telegraphy) decoders. The present circuit may also be used to imitate the sound of wind, mosquitoes, bees, and other buzzing insects.

The circuit consists of a relaxation oscillator, IC_1 , which is provided with positive and negative feedback via P_1 - R_2 and P_3 - P_2 - R_3 - C_1 respectively. Zener diode D_1 functions as noise source. The amplification of the noise is determined by the setting of P_3 (coarse) and P_2 (fine). The setting of P_1 determines the noise bandwidth: a small effective value results in a narrow band, and increasing values cause wider bands.

Due to the negative feedback, the



opamp also functions as a low-pass filter: a small feedback factor results in a low roll-off frequency. The pass band of the opamp also depends on the value of C_2 : a value of 47 n causes a noise similar to the buzzing

of a mosquito or bee. Diodes D_2 and D_3 serve as input limiters. The output level of the generator can be adjusted with P_4 .

Current consumption is not greater than 10 mA at 12 V.



brake lights monitor

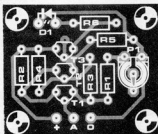
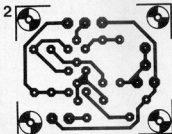
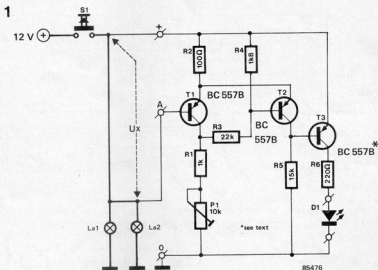
R Kambach

The circuit described below monitors your car's brake lights, and indicates by a light-emitting diode whether they both function correctly. In that sense, it can save you money by preventing your being fined for driving with defective brake lights, and it also leads to increased road safety.

The monitor depends inevitably on the voltage drop across the supply lines to the two lamps. For the circuit to work correctly, that drop needs to be greater than 0.6 V. If this is not so, the drop must be increased by adding a 5 A diode in series with each lamp. Transistor T_1 and T_3 in figure 1 form a Schmitt trigger, which reacts to the voltage drop across the supply lines to the two brake lights. This reaction manifests itself in D_1 lighting via T_3 . If one of the brake lights is faulty, the switch-on current drawn by the other lamp will cause D_1 to light briefly when the brake pedal is pressed. If both brake lights are defective, D_1 will not light at all. All three possible states of the brake lights are thus indicated.

The hysteresis of the trigger, and, therefore, the sensitivity of the circuit, can be adjusted within narrow limits with P_1 . The preset is best adjusted with one lamp out of action in a manner which makes D_1 light briefly as described above.

If you find it disturbing that D_1 lights every time you brake, the operation can be reversed by replacing the BC557B in the T_3 position by a BC547B (n-p-n). The collector of T_3 is then connected to the positive supply line, and the emitter to R_6 . On the printed circuit board this means that the flat edge of T_3 must be turned the other way. A second base connection has also been provided on the PCB. Note, however, that this configuration



Parts list

Resistors:

- $R_1 = 1 \text{ k}$
- $R_2 = 100 \Omega$
- $R_3 = 22 \text{ k}$
- $R_4 = 1\text{k}8$
- $R_5 = 15 \text{ k}$
- $R_6 = 220 \Omega$
- $P_1 = 10 \text{ k}$ preset potentiometer

Semiconductors:

- $D_1 = \text{LED}$, colour to taste
- $T_1 \dots T_3 = \text{BC557B}$ (but see text on T_3)

For Components Sources See Page 9-38

no longer makes it possible to ascertain whether one or both brake lights are faulty, i.e., when the LED lights, one or both lamps need replacing.

The printed circuit board is not available ready made.

In figure 1, S_1 is the brake pedal switch, and La_1 and La_2 are the brake lights.



lead-acid battery charger

Although in electronics more NiCd than PbH_2SO_4 batteries are used (or so we're told), there is still a healthy demand for good chargers for the lead-acid types. The present one enables 6- or 12-volt types to be charged rapidly; switches itself off automatically; and is protected against thermal overload, short cir-

cuits, and polarity reversal of the battery.

If you are not fully acquainted with modern sealed lead-acid batteries, here are some of its more important properties. It may be used in any position, even upside down. The charging voltage should be 2.3 V per cell (2.45 V for fast charging): i.e., 6.9 V

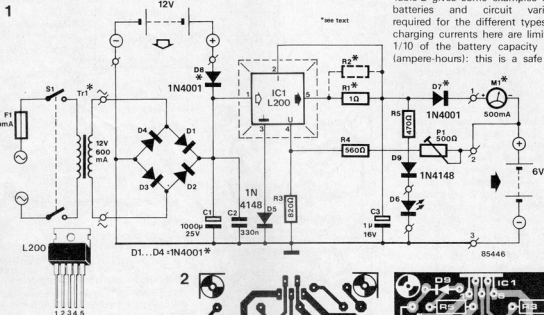
for a 6 V battery and 13.8 V for 12 V types. The charging current need not be limited to 0.1...1 C (= capacity in Ah — the actual figure depends on the manufacturer). The battery is charged when the charging current has dropped to 1 per cent of the capacity. Some manufacturers state that it is preferable that their batteries

Table 1.

condition		LED	meter
polarity correct	voltage at input	lights	400 mA
	no voltage at input	out	0 mA
polarity reversed	voltage at input	out	400 mA (!)
	no voltage at input	out	0 mA
battery not connected	voltage at input	lights	0 mA
	no voltage at input	out	0 mA

Table 2.

battery type	T_{r1}	$D_1 \dots D_4$ D_7, D_8	R_1	R_2	M_1
6 V 4 Ah	12 V; 0.6 A	1N4001	1 Ω	∞	0.5 A
6 V 6 Ah	12 V; 1.0 A	1N4001	1 Ω	2 Ω	1.0 A
6 V 8 Ah	12 V; 1.2 A	1N5401	1 Ω	1 Ω	1.0 A
6 V 10 Ah	12 V; 1.5 A	1N5401	0.82 Ω	0.82 Ω	1.0 A



Parts list

Resistors:

- $R_1 = 1 \Omega$
- $R_2 =$ see text
- $R_3 = 820 \Omega$
- $R_4 = 560 \Omega$ (see text)
- $R_5 = 470 \Omega$
- $P_1 = 500 \Omega$ preset (see text)

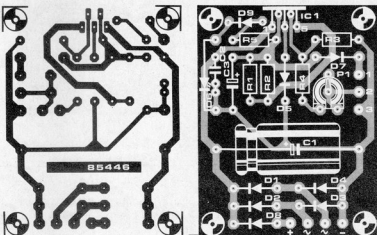
Capacitors:

- $C_1 = 1000 \mu/25 \text{ V}$ (see text)
- $C_2 = 330 \text{ n}$
- $C_3 = 1 \mu/16 \text{ V}$

Miscellaneous:

- $M_1 =$ moving coil meter, 500 mA f.s.d
 - $T_{r1} =$ mains transformer, secondary 12 V, 600 mA (see text)
 - $S_1 =$ DPST mains on/off switch
 - $F_1 =$ fuse, 100 mA, delayed action
 - heat sink for IC₁ (optional - see text)
- Semiconductors:
- $D_1 \dots D_4, D_7, D_8 = 1\text{N}4001$
 - $D_5, D_9 = 1\text{N}4148$
 - $D_6 = \text{LED}$
 - $IC_1 = \text{L}200$

For Components Sources
See Page 9-38



are charged in a horizontal position. Never charge these batteries with a NiCd battery charger!! The circuit of the suggested charger is based on a type L200 voltage regulator which ensures a constant charging voltage. The actual level of the charging voltage is set with P_1 in the absence of a battery. Resistors R_1 and

R_2 provide current limiting, but R_2 is only necessary if a charging current above 0.5 A is required or to enable the output current more precisely. The current is limited to $[0.45(R_1 + R_2)/R_1 R_2] A$; its actual value is indicated by M_1 .

The L200 may be mounted on a small heat sink, but this is not strictly necessary since the device has internal thermal protection.

Normally, the battery charger works from the mains, but it can also operate from a 12 V (car) battery.

All possible situations, some of which are highly undesirable, are enumerated in table 1. The one exception is that when the battery is really flat, the table does not apply. The battery must then be seen to be connected correctly to the charging terminals. Also, the LED indication will then initially not work.

Table 2 gives some examples of 6 V batteries and circuit variations required for the different types. The charging currents here are limited to 1/10 of the battery capacity in Ah (ampere-hours): this is a safe value

which is permissible under all circumstances).

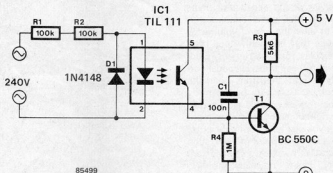
If the charger is required for 12 V batteries, the mains transformer must have a secondary voltage of at least 18 V, and capacitor C_1 must become a 35 V type. Furthermore, resistor R_4 should be increased to 1k8 and preset P_1 to 1 k Ω .



mains interface

This circuit is of use, for instance, when a computer is required to monitor a mains-operated equipment. Opto-isolator TIL111 ensures complete isolation between the mains and the computer.

With the mains on, during every positive half-wave a current of about 1 mA flows through the LED in the opto-isolator. The associated transistor then conducts and its collector current of about 100 μ A is sufficient to drive T_1 . Remember, however, that this is a pulsating current: capacitor C_1 ensures that T_1 conducts continuously as long as the mains is on. If a 50 Hz square wave is required at the collector of T_1 , C_1 should, of course, be omitted.



The two 100 k resistors in series with the LED should not be replaced by one 220 k resistor, because the maxi-

mum permissible voltage drop across a standard $\frac{1}{4}$ W resistor should not exceed 150 V_{rms} .



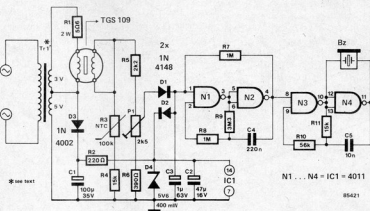
smoke and gas detector

This circuit is intended for use as a preventive device. We all know about accidents that occur through the accumulation of gas or of people overcome by smoke. The preventive character manifests itself by timely warnings in case of high gas concentrations in a manner that does not cause the gas to explode.

The circuit is based on sensor type TGS109 which is sensitive to gases enumerated in the accompanying table.

Power is provided by an 8-volt bell transformer which is tapped at 5 V. The voltage developed across the 5 V winding is rectified by D_3 , smoothed by C_1 , and regulated by R_2 , D_4 , and C_2 . The resulting direct voltage of about 5.6 V is used to supply IC₁. The 3 V alternating voltage is used to operate the sensor, which needs 1 V at about 0.5 A. Resistor R_1 provides the necessary voltage drop.

The mutual inductance between the two windings of the sensor increases with rising gas concentrations. Note that there is no difference in the two windings: the sensor may therefore be inserted into the socket in any way it fits. In practice, a rising gas concentration will cause an increased alternating voltage in the secondary winding of the sensor. This voltage is rectified in D_1 and smoothed by C_3 ; its level (=sensitivity) is preset with P_1 . Diode D_2 protects one of the inputs of N_1 against too high input levels. Gates N_1 - N_2 and N_3 - N_4 are



TGS 109

astable multivibrators which cause the buzzer to operate when there is too high a concentration of gas.

Resistor R_3 serves to counteract changes in sensitivity caused by temperature variations.

The detector can be built into a small case, but bear in mind the heat dissipation in R_1 .

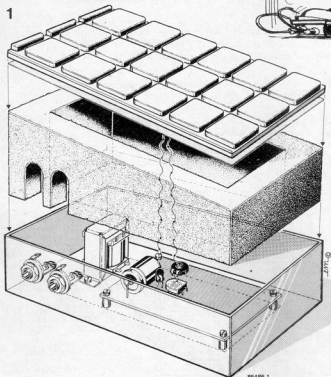
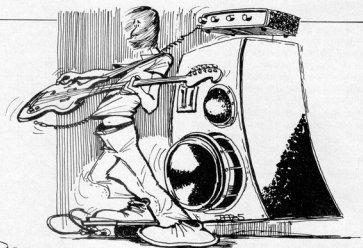
Finally, in case of an alarm, be careful in the inspection of the relevant room or space for which the alarm is sounded.

Table

Hydrocarbons:	iso-butane $CH_3CH(CH_3)CH_3$ n-butane $CH_3CH_2CH_2CH_3$ ethane CH_3CH_3 propane $CH_3CH_2CH_3$ $CH_3CH_2CH_2CH_3$ methane CH_4
Inorganic gases:	hydrogen H ammonia NH_3 carbon monoxide CO
Organic solvents:	ethanol CH_3CH_2OH acetone C_3H_6O , CH_3COCH_3 n-hexane $CH_3(CH_2)_4CH_3$ benzene C_6H_6

swell pedal

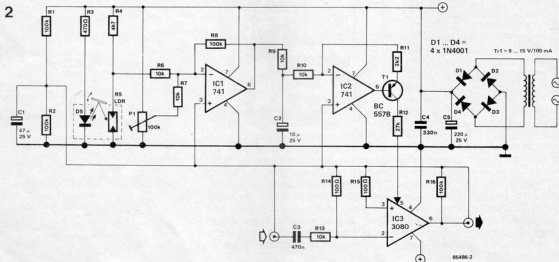
Reminiscent of the accelerator pedal in a car, a swell pedal enables musicians to alter the sound volume by foot, since they invariably need both hands to play their instrument. Electronic organs have the swell pedal normally built into the front near the other pedals. Guitarists have to buy this almost indispensable aid for getting the right blend of accompaniment and solo voice(s) as an optional extra. From an electronic point of view, such commercially available devices are simplicity itself: normally nothing



more than a potentiometer operated by the foot pedal via a toothed bar. The mechanics, however, make home construction a rather more daunting task. The swell pedal described here avoids the mechanical intricacies.

The circuit is entirely contained in a flat case of about the shoe-size of the user — see figure 1. A wedge-shaped, hollowed-out piece of foam rubber is glued onto the lid of the case. A light-emitting diode, D_5 , and a light-dependent resistor, LDR, protrude from the lid. A small sheet of metal or plastic, the underside of which is covered with white paper or cardboard, is then glued onto the foam rubber. The top of the metal or plastic sheet may be covered (glued) with a small rubber mat.

When the foam rubber is compressed by foot pressure, the reflective white paper or cardboard comes nearer to the LED and LDR, which causes the resistance of the LDR to diminish.



Because of the amplifying, inverting, and compensating action of IC₁, a voltage is applied to IC₂ which is used to control the drive current provided by transistor T₁ for OTA (operational transconductance amplifier) IC₃.

After the pedal box has been glued together, so that the electro-optical components are in a light-proof chamber, adjust P₁ so that with non-operated pedal the sound volume is just at the right level for accompani-

ment. For solo playing, the pedal is depressed as required to obtain the increased sound volume. It is advisable to fit P₁ in the side of the pedal case as shown, so that it can be re-adjusted at a later date if required.



spot frequency receiver

Monitoring a number of frequencies in the short-wave band, such as the international shipping distress frequency, is a fascinating pastime. Since only a limited number of stations is normally monitored, and their frequency is invariably fixed by international treaty, the receiver needs only to be capable of being switched between those spot frequencies.

The receiver works on the direct conversion principle, i.e., the oscillator frequency is equal to the received frequency, so that the intermediate frequency is zero.

The aerial signal is fed to tuned RF amplifiers T₁ and T₂ via a switch preselector. The RF amplifiers are coupled to an S042P type mixer. There are three crystal-controlled local oscillators, which are switched into circuit in accordance with the preselector.

The output of the mixer is the audio signal, which is fed to AF ampli-

fier IC₂ via low-pass filter R₁₁...R₁₃, C₂₈...C₃₀. The gain of IC₂ is about 60 dB.

Part of the output of IC₂ is rectified in D₁ and D₂ and used for AGC (automatic gain control) of T₁ and T₂. The output of IC₂ is fed to power amplifier IC₃ which drives a loudspeaker or headphones. There is also a tape output. Volume control is provided by P₁.

Inductors L₁...L₃ are each wound on a T50/2 toroid as follows:

- L₁ = 115 turns enamelled copper wire of 0.15 mm dia. with tap at 11 turns;

- L₂, L₃ = 90 turns enamelled copper wire of 0.2 mm dia. with tap at 9 turns.

If different frequencies from those shown are required, one or more of the crystals must, of course, be replaced, but at the same time L₁, L₂, or L₃, as appropriate, must also be modified. The change in the number

of turns and the tap is directly proportional to the change in frequency. If, for instance, a frequency of 2600 kHz instead of 2182 kHz is wanted in position 1 of switch S₁, the number of turns, n, of L₁ should become

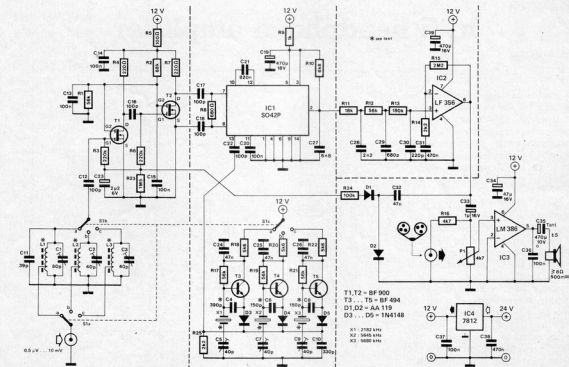
$$n = 115(2182/2600) = 97 \text{ turns}$$

and the tap should be at

$$n = 11(2182/2600) = 9 \text{ turns.}$$

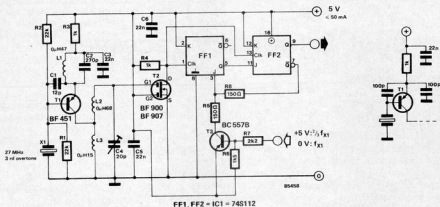
Oscillator capacitors C₄, C₆, and C₈ should have a higher value if the frequencies are chosen at the low end of the short-wave band.

When the receiver has been built correctly in accordance with HF requirements (short connections, ample decoupling), it should work up to about 18 MHz. The dashed lines in the circuit diagram represent earthed screens between the various sections. The receiver is calibrated by adjusting C₅, C₇, and C₉ for zero beat, and then adjusting C₁, C₂, and C₃ for maximum audio output.





two-frequency clock



Many computer systems use one clock signal, from which all other timing signals are derived. The frequency of the clock signal determines, among others, the maximum number of characters per line the video controller can display on the monitor screen. This is normally 32 or 40. If more characters per line are required, the clock frequency has to be increased. The clock generator described here makes it possible to switch between frequencies which are related

in a ratio of 2:3. The switching is carried out synchronously, so that no bits are lost.

The clock oscillator, T_1 , is controlled by an inexpensive 3rd overtone 27 MHz crystal, XL_1 . The LC circuit connected to the collector of T_1 is tuned to 54 MHz. The 54 MHz signal is converted to logic bits by field-effect transistor T_2 which are then applied to the Q inputs of dual J-K bistable IC $_1$ (= FF $_1$ /FF $_2$). The ring counter formed by these bistables can

be changed over by T_3 . When T_3 is on, the J input of FF $_1$ is logic high, and the 54 MHz signal is divided by 2. When T_3 is off, the J input of FF $_1$ is connected to the \bar{Q} output of FF $_2$ and the 54 MHz signal is then divided by 3. The output frequency can thus be switched synchronously between 18 MHz and 27 MHz.

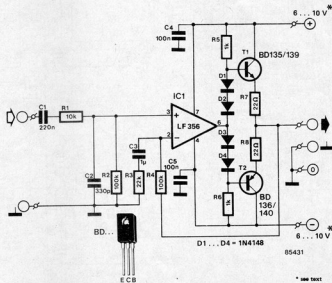
If a fundamental crystal is used in the XL_1 position, the oscillator can be modified as shown inset.

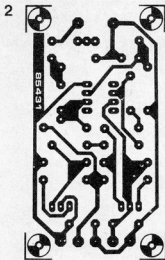


hi-fi headphone amplifier

This 1-watt amplifier lends itself *par excellence* for use as driver for a low impedance headphone or as output stage in a hi-fi preamplifier driving an active loudspeaker. Many preamplifiers do not permit long, unscreened leads to be connected to them, but the present amplifier accepts these happily.

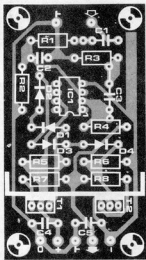
The circuit — figure 1 — consists of an opamp type LF 356 and a push-pull transistor output stage. Low-pass filter R_1/C_2 at the input limits the slew rate of the input signal. In conjunction with the relatively fast LF 356, this results in very low delay distortion. The fixed quiescent current of 30 mA drawn by the output transistors, and set by diodes $D_1 \dots D_4$ in conjunction with emitter resistors R_7 and R_8 , ensures very low crossover distortion. Feedback resistors R_3 and R_4 fix the gain at about 15 dB. The consequent overall distortion with a -3 dB bandwidth from 10 Hz to 30 kHz is only 0.1 per cent.





The amplifier delivers a maximum power of 1 watt into 8Ω for an input signal of about $500 \text{ mV}_{\text{rms}}$. High-impedance headphones and 4Ω loudspeakers may also be connected without detriment.

The amplifier is best built on the printed circuit board shown in figure 2. To enable it surviving a short circuit at the output, the two tran-



Parts list

Resistors:

- $R_1 = 10 \text{ k}$
- $R_2, R_4 = 100 \text{ k}$
- $R_3 = 22 \text{ k}$
- $R_6, R_8 = 1 \text{ k}$
- $R_7, R_5 = 22 \Omega$

Capacitors:

- $C_1 = 22 \text{ n}$
- $C_2 = 330 \text{ p}$
- $C_3 = 1 \mu$
- $C_4, C_5 = 100 \text{ n}$
- $D_1 \dots D_4 = 1\text{N}4148$
- $T_1 = \text{BD } 135 \text{ or } \text{BD } 139$
- $T_2 = \text{BD } 136 \text{ or } \text{BD } 140$
- $\text{IC}_1 = \text{LF } 356$

Miscellaneous:

- PCB 85431
- Heat sinks for T_1 and T_2
- For Components Sources See Page 9-38

sistors should be mounted on heat sinks — do not forget the insulating washers and the heat conducting paste!

The power supply need not be more than a simple affair, consisting of a mains transformer with a centre-tapped, $6 \dots 8 \text{ V}$, 0.5 A secondary, a suitable bridge rectifier, and two $1000 \mu\text{F}/16 \text{ V}$ electrolytic capacitors in

a conventional arrangement.

To drive high-impedance headphones at high volume, you need a $\pm 15 \text{ V}$ regulated power supply; in some cases, this may be derived from the preamplifier supply. In this arrangement, care must be taken not to short-circuit the output terminals.

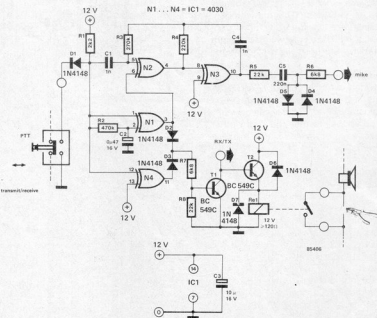


send/receive ident

Some radio amateurs like to give an identification signal at the beginning and end of a message; others frown upon this practice which they find disturbing. If you belong to the first group, you may find this circuit useful as it gives an ident signal automatically when the transmit/receive key is pressed and just after this has been released again. The two signals are identifiable by being slightly different in frequency.

XOR gate N_1 functions as a monostable, whose output is high for a short time after its inputs either change from high to low (at the onset of a transmission), or from low to high (at the end of a transmission). Its output is applied to an oscillator, N_2/N_3 , and to the transmit/receive switching section. When the input pin 6 of N_2 is high, this XOR gate functions as an inverter, so that the oscillator generates a short tone in the medium audio range which is fed to the microphone via limiter D_4/D_5 . The frequency determining network is earthed via C_1 and D_1 or via C_1 and R_1 , depending on whether the transmit/receive key is pressed or has just been released.

During transmission, the rx/tx output



is low: this output is intended to be connected to the corresponding input of the transceiver. Transistor T_2 is on, so that relay Re is actuated: its contact(s) may be used, for instance, to

disconnect the loudspeaker during transmissions.

Current consumption, ignoring the relay current, amounts to about 15 mA .

combining digital circuits

Many electronics hobbyists combine all sorts of digital circuits into works to be marvelled at. However, even they sometimes have that uncertain feeling: must they all be powered by one unit or should there be more or can there be more? And in what sequence should they be switched on? Printer first, or computer first?

In digital engineering, which by definition embraces computers, inputs are driven by outputs: information is being transferred. When the IC that drives has a power supply, but the receiving one has not, a current will ensue, whether the circuits are TTL or CMOS. This is an undesirable situation, although it does not normally lead to damage. But the ensuing current may be so large that the IC providing the current does not operate efficiently any more, because its output voltage, owing to the large current, becomes too low. Particularly bistables can become disorganized by this. It is, therefore, possible that a certain equipment does not work properly because another circuit connected to it does not have a power supply.

That situation can become really critical when several outputs of an IC are terminated in that manner. Normally, an IC can withstand a short at one of its outputs, but if that happens at several outputs, the IC will probably give up the ghost. This may happen, for instance, in the case of a Centronics interface, of which the eight data lines are normally driven by one IC.

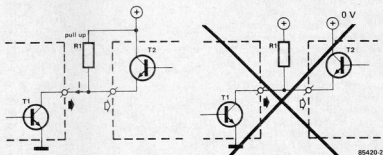
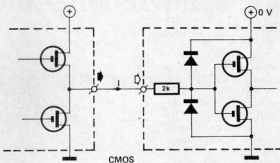
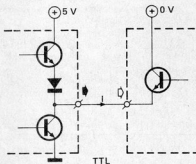
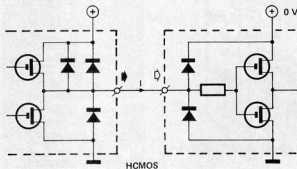
And what happens to the IC that is provided with the current? CMOS circuits are generally well protected against this, and TTL devices normally stand up well to them also. But other types may not take so kindly to these currents.

Semiconductor manufacturers have, of course, also been confronted with these problems and have found solutions to them. Anyone designing and building his own circuits should, therefore, heed their experiences and observe the following rules.

■ Driver ICs, whether TTL or CMOS, must have an open-collector output.

■ All inputs should be provided with additional resistance (pull-up resistors) to the positive supply line.

If these rules are adhered to, current can only flow from input to output (see figure 2). This does not matter, because the collector of transistor T_1 can stand quite a high voltage and nothing will, therefore, go wrong. Make sure that the pull-up resistor is



connected at the input side, otherwise it has no effect.

As to the question at the beginning: it does not matter which unit is

switched on first, because the IC manufacturers have made sure that the input and output circuits are protected.



video distribution amplifier

To feed a number of high-resolution monitors from one source (computer, video recorder), an amplifier is required that, apart from a reasonable gain, has a wide bandwidth. Unfortunately, these two requirements are not completely compatible, but the design presented here offers a fair compromise.

The circuit is capable of driving five 75 Ω loads simultaneously: the bandwidth at each of the outputs is 30 MHz. It consists of a differential amplifier, T_1 - T_2 , which is followed by a fast emitter follower formed by T_4 and T_5 . The gain of the differential amplifier is about 23 dB.

Transistors T_3 and T_6 are current sources of 30 mA and 200 mA respectively.

Feedback network R_7 - R_8 - R_9 - C_3 - C_4 ensures a bandwidth of around 50 MHz and a level pass band. Capacitor C_5 stabilizes the amplifier in the high-frequency region.

When all five outputs are loaded, the bandwidth reduces to about 30 MHz, and the pass band then shows variations of around 2 dB. The overall gain is a respectable 8 to 10 dB.

The printed circuit board (which is not available ready made) is shown in figure 2. Because of the high current through T_5 and T_6 , both these transistors should be fitted onto a suitable heat sink.

As the total current consumption of the circuit is around 250 mA, a separate power supply will be required in almost all applications.

Parts list

Resistors:

- $R_1 = 6k8$
- $R_2 = 2k2$
- $R_3 = 1k$
- $R_4 = 33 \Omega$
- $R_5 = 100 \Omega$
- $R_6, R_7 = 330 \Omega$
- $R_8 = 120 \Omega$
- $R_9 = 680 \Omega$
- $R_{10} = 4k7$
- $R_{11} \dots R_{15} = 82 \Omega$
- $P_1 = 100 \Omega$ preset potentiometer

Capacitors:

- $C_1, C_4, C_7 = 1 n$
- $C_2 = 22 \mu/10 V$
- $C_3 = 100 \mu/10 V$
- $C_5 = 18 p$
- $C_6 = 470 n$
- $C_8 = 470 \mu/10 V$

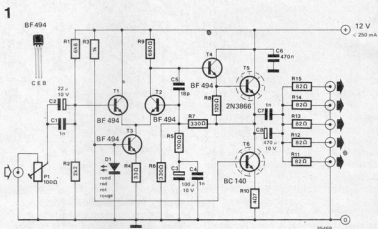
Semiconductors:

- $T_1 \dots T_4 = BF494$
- $T_5 = 2N3866$
- $T_6 = BC140$
- $D_1 = LED, red$

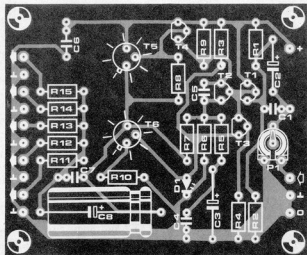
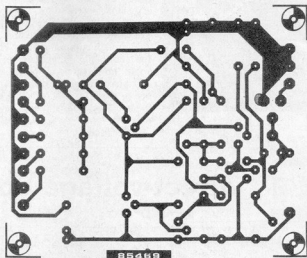
Miscellaneous:

- 2 heat sinks T039

For Components Sources See Page 9-38



2

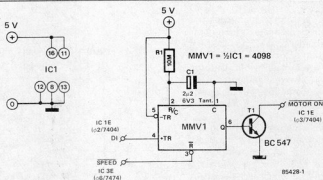
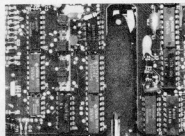




floppy centring unit

In modern disk drive mechanisms, as, for instance, the TEAC FD55x, the motor starts automatically when a disk is inserted into the drive. When the lid is closed, the motor stops again. This arrangement ensures better centring of the disk. Better centring means less wear on the centre fixing hole, the life of the disk is extended, and read/write errors owing to eccentricity off the disk are prevented.

Owners of older drive mechanisms, such as the BASF 6106, can incorporate that facility with the circuit proposed here. The signal from the write protect phototransistor is used to determine when a disk is being inserted (this signal is normally gated when the drive is closed), and to start the motor for the total period of



monostable MMV1. The SPEED signal is not absolutely necessary: it stops the motor direct when the lid is closed. If it is not used, pin 3 must be connected to the +5 V line. The motor will then run for the duration of the period of MMV1, i.e., about 10 s. The monostable period can be reduced by lowering the value of the capacitor.

The points where to connect the circuit in the 6106 are easy to find. Looking at the pcb from the front, you will see a cut-out in the front centre of the board. Immediately to the left of this are three ICs (see photograph). The one at the front is a 7474, the one in the middle a 7432, and the one at the

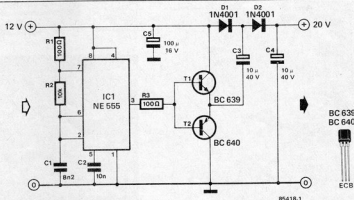
back a 7404. The signal SPEED is taken from pin 6 of the 7474, and the signal DI from pin 2 of the 7404. The signal MOTOR ON is applied to pin 3 of the 7404. As all existing connections remain, the connecting wires of the auxiliary circuit can be soldered direct to the relevant IC sockets. In the same way, it is possible to derive the supply voltage for the auxiliary circuit: for instance, +5 V from pin 14 of the 7404, and 0 V from pin 7 of this IC. It is important to note that there are two types of pcb used in 6106 drives: the ICs and the IC function are the same in both versions, but the construction may look different from that shown in the photograph.



direct-voltage doubler

A direct-voltage doubler is particularly useful when from an available supply voltage a higher one has to be derived. As the current in most such cases is pretty small, the cost of a suitable circuit can be kept down.

Astable multivibrator IC₁ is a rectangular-wave generator operating at about 8.5 kHz whose output drives transistors T₁ and T₂. When the level at pin 3 of IC₁ is low, T₁ is off and T₂ conducts. As the negative terminal of C₂ is then connected to earth, the capacitor charges via diode D₁. When the output of IC₁ is high, T₂ is off and T₁ conducts. Capacitor C₃ cannot discharge because of D₁, but C₂ charges to a voltage roughly equivalent to the supply voltage of +12 V and the p.d. across C₃ and D₁. In our prototype, this voltage across C₄ amounted to 20 V approximately. The maximum current should not exceed 70 mA: at that value, the output voltage is 18 V, at an efficiency of thirty-two per cent.



We have not tested the circuit with other supply voltages, but it can be safely assumed that it can be used over the whole supply voltage range of the NE 555.

Construction is possible on a small piece of prototyping board, after which the doubler can be fitted inside the power supply unit.

If a regulated output is required, it is possible to connect an appropriate voltage regulator, for instance, in the 78LXX series, but in that case the power requirements of the regulator must, of course, be taken into consideration when the maximum load current is calculated.



mini amplifier

This little amplifier, operating from 3...9 V, and providing 1 W output into a 4 Ω loudspeaker, is one of those circuits of which you never have enough.

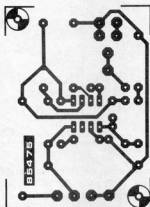
The amplifier is based on one 8-pin DIL IC type LM1895N. Electrolytic capacitors C_2 and C_6 decouple the supply lines; C_7 prevents d.c. reaching the loudspeaker; and C_3 and C_5 provide a low-impedance path to earth for audio frequencies.

The input signal is applied to pin 4 of the LM1895N via P_1 and C_4 . Resistor R_4 and capacitor C_8 suppress any tendency to oscillation, i.e., improve the stability.

The amplification is determined by R_1 and R_2 ; it is of the order of 50. Capacitor C_1 , in parallel with R_1 , ensures that the amplification drops off for frequencies above about 20 kHz. If the amplifier is intended for use with a small AM receiver, it is desirable that the amplification starts falling off at a lower frequency. This is brought about by enlarging C_1 ; for instance, if its value is doubled, the amplification starts dropping at $20/2=10$ kHz.

On the printed circuit board shown in figure 2 (which is not available ready made), P_1 may be replaced by a wire link; the volume control is then carried out by an external logarithmic poten-

2



Parts list

Resistors:

- $R_1 = 10$ k
- $R_2 = 47$ Ω
- $R_3 = 220$ Ω
- $R_4 = 1$ Ω
- $P_1 = 50$ k linear preset potentiometer (see text)

Capacitor:

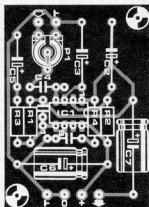
- $C_1 = 470$ p (see text)
- $C_2 = 220$ μ/10 V
- $C_3 = 100$ μ/10 V
- $C_4, C_8 = 100$ n
- $C_5 = 10$ μ/10 V
- $C_6, C_7 = 470$ μ/10 V

Semiconductors:

IC1 = LM1895N

Miscellaneous:

- Loudspeaker, 1 W, 4 Ω
- For Components Sources See Page 9-3B

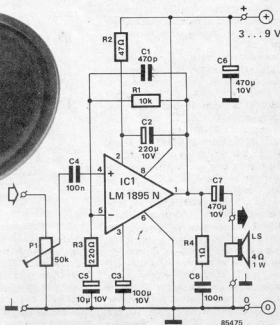
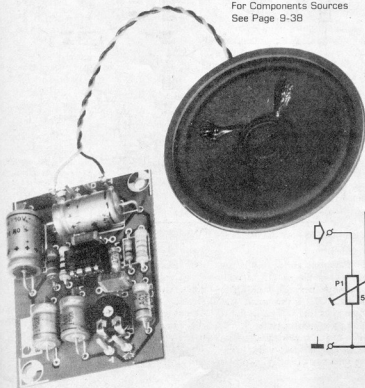


tiometer connected to the PCB via a short length of screened audio cable. Current consumption is 2.5 mA at 3 V or 7.5 mA at 9 V under no-signal conditions, and 80 mA at 3 V or 270 mA at 9 V under fully driven conditions: in the latter condition, the output power is 100 mW or 1 W respectively into 4 ohms.

The output power for different supply voltages and loudspeaker impedances can be estimated by deducting 1 V from the supply voltage, and raising the result to the power 2. Divide the number obtained by 8 and then again by the loudspeaker impedance.

The sensitivity of the amplifier is about 50 mV. This can be reduced by lowering the value of R_1 .

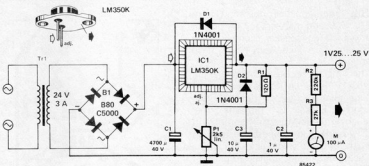
National Semiconductor Application.





variable 3 A power supply

As far as construction is concerned, this is a real mini power supply, but it can deliver up to 3 A at an output voltage of 1.25...25 V. Note, however, that integrated voltage regulator IC₁ has on-chip overload protection that comes into operation when the dissipation in the device reaches 30 W. The ADJ(ust) pin of the regulator is connected to the junction of potential divider R₁-P₁. The output voltage, U_o, is calculated from $U_o = [1.25 (1 + P_1/R_1)] V$ where P₁ and R₁ are in ohms (the value of P₁ is measured between the wiper and the junction with R₁, i.e., 0...2.5 kΩ). Capacitor C₁ is a conventional filter capacitor, while C₂ and C₃ improve the regulation. Protection diodes D₁ and D₂ ensure that at switch-off the potential at the output of IC₁ is more positive than that at its input. The value of R₁ has been chosen to



ensure that the minimum load current through IC₁ is about 3.5 A.

It is essential that IC₁ is mounted on a heat sink rated at about 1 K/W — do not scrimp on the heat conducting paste!

When only low output voltages are needed, it makes sense to use a mains transformer with a lower secondary voltage (for U_o = 5 V, the secondary

voltage should be 9 V). When a 24 V secondary is used, and the required output voltage is 1.25 V, the maximum output current is 1 A, otherwise the maximum dissipation of the LM 350 is exceeded, and the internal protection will switch off the regulator. When the secondary voltage is 9 V, and U_o = 1.25 V, the maximum load current amounts to 2.5 A.



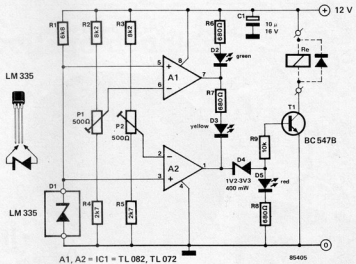
heat sink monitor

R Jacobs

In almost any equipment in which a reasonable amount of energy is consumed, there is bound to be at least one heat sink that enables power semiconductors to get rid of their excess heat. The rating of a heat sink is normally determined on the basis of the maximum allowable temperature of the silicon chip: a rather haphazard method.

The heat sink monitor described here constantly monitors the temperature of the heat sink. When that temperature stays below 50...60°C, the green LED lights; between those temperatures and 70...80°C, the yellow (orange) LED lights; and above 70...80°C, the red LED lights. There is also the possibility of providing a relay with which, for instance, the load can be disconnected.

The circuit is, in essence, a window comparator, in which sensor D₁ provides a control voltage that rises 10 mV per degree Celsius. If the sensor voltage is lower than the voltage at the wipers of P₁ and P₂, the outputs of opamps A₁ and A₂ are low, and D₂ lights. When the voltage across D₁ lies above that at the wiper of P₁, but below that at the wiper of P₂, the output of A₁ is high, so that D₂ goes out and D₃ lights. When the



sensor voltage rises above that at the wiper of P₂ also, the output of both opamps is high: only D₃ then lights and transistor T₁ is switched on. Zener D₄ ensures that D₂ lights brightly and that T₁ conducts hard.

To calibrate the unit, place the sensor, together with a calibrated thermometer, in a tray of water, which is

then heated. Set P₁ to minimum and P₂ to maximum resistance. Set the cross over from green to yellow (orange) between 50 and 60 degrees Celsius with P₁. Next, set the cross over from yellow (orange) to red between 70 and 80 degrees Celsius with P₂. The sensor can then be fitted permanently onto the heat sink.



6502 tracer

A program that has been written into an assembler will rarely run error free on the first run. It often exhibits blurbs and other ramblings: in bad cases, there is a complete hang up and it is then necessary to start the computer afresh with a RESET.

To find such faults in a relatively easy manner, the tracer described here will be found very useful.

The circuit layout of the tracer is shown in figure 1. Gate N_1 is an address decoder, whose output in the address range $\$F000.. \$FFFF$ is logic 0. NAND gate N_2 is fed with the SYNC signal from the computer and the 0 signal; it is disabled by either the address decoder, N_1 , or bistable FF_2 . The address decoder disables N_2 when the EPROM is addressed from the CPU. This prevents the SYNC line of the 6502 processor generating an MI (maskable interrupt). If the processor passes through a machine program somewhere in the RAM, N_2 generates an interrupt as soon as the processor reads an opcode, which makes the SYNC line logic 1. This non-maskable interrupt directs the processor to an interrupt program in the monitor program. All CPU registers are safeguarded by this interrupt program and subsequently displayed on the monitor screen. At the same time, the processor disassembles the next command.

Parts list

Resistors:

- $R_1 = 1\text{ k}$
- $R_2 \dots R_4 = 10\text{ k}$
- $R_5 = 220\ \Omega$

Capacitors:

- $C_1 = 10\ \mu\text{F}/16\text{ V}$
- $C_2 = 100\text{ n}$

Semiconductors:

- $D_1 = \text{LED (red)}$
- $IC_1 = 74LS22$
- $IC_2 = 74LS74$

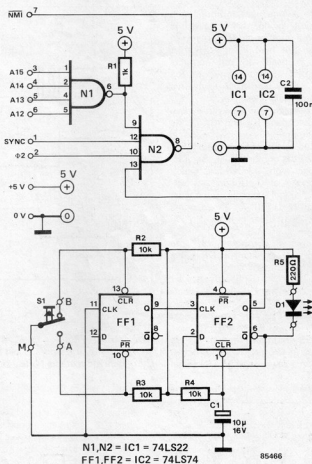
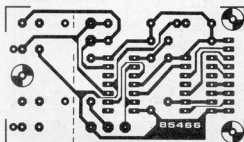
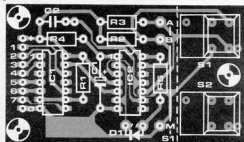
Miscellaneous:

- $S_1 = \text{miniature spring-loaded press-to-make switch}$
- $S_2 = \text{miniature spring-loaded press-to-break switch (see text)}$

For Components Sources

See Page 9-38

2



The programmer can, therefore, see beforehand under what conditions the processor starts with the execution of the next opcode. Since the status register and all its flags are also displayed on the screen, the programmer can easily ascertain whether a flag in the status register has been set incorrectly.

Bistable FF_1 serves as a debounce stage; FF_2 toggles on receipt of a leading edge from FF_1 : that is, every time S_1 is pressed. When the tracer is switched on, D_1 lights. Resistor R_2 and capacitor C_1 form a power-on reset network that automatically

switches the tracer off when the computer is switched on.

The printed circuit board for the tracer is shown in figure 2. If you want to build the tracer into the computer case, the PCB can be cut along the dashed line, so that the section containing the tracer and S_2 may be fitted in the most convenient position. Switch S_1 must be connected to the tracer via a suitable cable, but S_2 may be connected to the manual RESET of the system.

Information on software for the tracer may be found in our books on the Junior Computer.

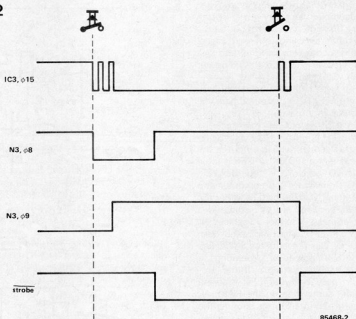
There are various ways of producing a hexadecimal keyboard. Normally, it is based on a number of key contacts in a matrix, but here a rather simpler method is used: 16 key contacts (0...F) that are commoned to the positive supply line. Such keyboards are commercially available.

Code conversion is carried out by two priority encoders, IC₃ and IC₄. If one of the inputs I₀...I₇ of these ICs is connected to the positive supply line via one of the contacts S₁...S₁₆, i.e., made logic high, the relevant binary code appears at the associated output, Q₀...Q₂, of which Q₀ is the least significant bit (LSB). As the encoders are cascaded, there is a total of 16 inputs.

Corresponding outputs of the encoders are combined in OR gates N₆...N₈ to form the lowest three output bits D₀...D₂; the fourth data bit is taken from the GS (group select) output of IC₃. This output is logic high when one of key contacts S₉...S₁₆ (8...F) is closed.

As the GS outputs of the two ICs are combined in OR gate N₅, D₃ is active high when a key is pressed. The signal

2

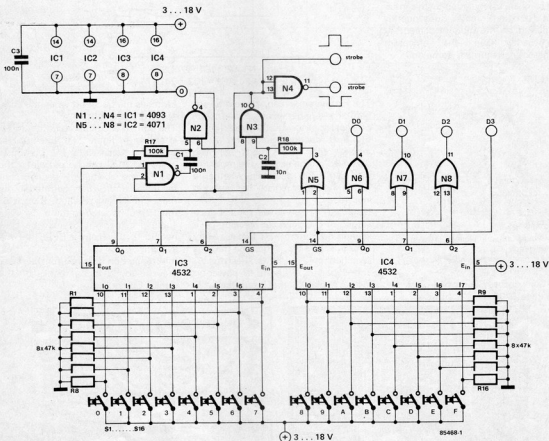


85468-2

at pin 9 of N₃ is delayed by R₁₈C₂. At the same time, the signal at pin 15 of IC₃ triggers monostable N₁-N₂. During

the pulse period of about 10 ms, pin 8 of N₃ is logic low so that, independent of the delayed signal at pin 9, the

1



85468-1

output of N_2 remains logic high. If pin 9 of N_2 is still high when the pulse begins to decay, the output of N_2 goes low and remains so until pin 9 becomes logic 0 again. During this time, pin 6 of N_2 remains low, so that

the monostable cannot be triggered erroneously. The timing diagram in figure 2 further clarifies the operation, which results in a debounced strobe or strobe pulse.

If more than one key is pressed, the

highest is selected, as is to be expected from a priority encoder! The circuit requires a power supply of 3...18 V; current consumption is not greater than 10 mA.



wah-wah box for guitars

In this day and age of electrophonics, a wah-wah box is still a popular means of animating an otherwise tired sounding guitar. Such a box, which is basically a high-Q low-pass or band-pass filter, can be designed in various ways. Early designs were invariably based on active (transistorized) double-T filters.

The present circuit, using opamps and operational transconductance amplifiers (OTAs), is rather more complex but also more efficient and more reliable.

Three pairs of opamps, each consisting of an OTA and a buffer amplifier, in conjunction with capacitors C_2 , C_3 , and C_4 , form a low-pass filter. Since the usual series resistances have been replaced by voltage-controlled current sources (OTAs), the roll-off frequency of the filter is determined by the currents flowing into pin 5 of the 3080s. These currents are themselves directly proportional to the input control voltage, U_c , which has been converted in A_1 and T_1 . This voltage, which is derived from a swell pedal, can have any value between 0 V and about 12 V.

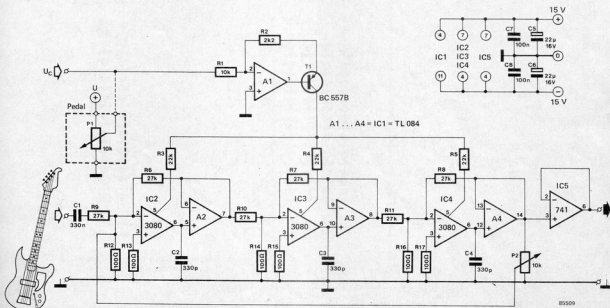
The negative feedback from output to



input enables the Q of the filter to be set with P_2 .

The swell pedal may be constructed as described elsewhere in this issue: it can actually be installed in one case together with this wah-wah filter! As it is difficult to describe sounds, and we are sure that the guitar players

among our readers will in any case experiment themselves, we will not dwell on what to expect from this musical adjunct. No calibration is needed: the box works or it does not! We hope the former.





jumbo displays

Although this project will not be of interest to everybody, it has many possible applications. The name refers to the respectable dimensions of the seven-segment displays:

280 x 140 mm. These sizes immediately indicate that the displays are intended to make alphanumeric information legible at a distance. This is of import, for instance, for score boards, speed indicators, lap counters, digital church clocks, etc.

These displays have a number of advantages:

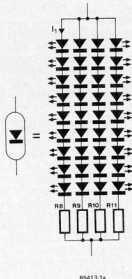
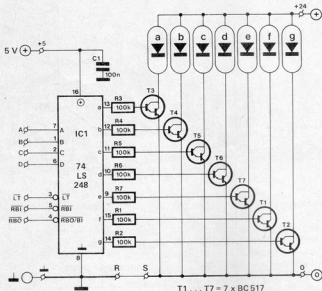
- they are entirely solid state, which prevents segment failure since the life of LEDs is much longer than, for instance, that of incandescent lamps;
- they do not need intricate reflector constructions;
- if any one LED fails, they remain fully legible by virtue of the special segment construction;
- they are easily arranged in a variety of colours — red, green, blue, yellow, orange;
- they work from 24 V with relative high efficiency, which keeps heat

dissipation low.

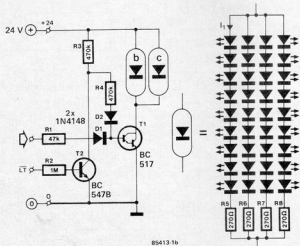
It may be said that the large number of LEDs required is a disadvantage, but, in our opinion, this is largely negated by the advantages.

The seven-segment display, shown in figure 1a, is based on a type 74LS248 decoder, which has the same features as the well-known type 74LS47/247, but has in addition internal pull-up resistors and inverted output signals, so that external transistors can be used to cope with the large currents drawn by the segments. The inputs

1a



1b



1c



Figure 1. Circuits for the control of (a) a seven-segment display; (b) a "1" display, and (c) a ":" display.

Figure 2. Correlation between the input and output signals of a 74LS248 decoder and a seven-segment display.

2



and outputs to the decoder, the read-outs, and the additional functions are correlated in figure 2.

All input and output controls have been arranged external to the decoder, so that they can be used in the same way as with normal displays. Wire link R-S serves to interconnect the earths of the +5 V and +24 V supplies.

At the output of the decoder there is a switching stage for each segment that switches the relevant segment on or off.

Each segment consists of four parallel groups of eight or nine LEDs in series with a current limiting resistor.

The displays can be powered from a non-stabilized 20...24 V supply. The current drawn per segment varies from 50 mA to 100 mA.

Figures 1b and 1c give the diagrams for displays with a "1" and a ":" respectively. Both can be used for a 12-hour clock. The "1" display has provision for a lamp test (LT); open inputs are considered active, i.e., the display lights. This is in contrast to the seven-segment display which treats inputs that are not connected as logic high, that is, inactive.

As mentioned earlier, read-out boards consisting of several figures may be composed by mounting a number of displays side by side on a flat base. The whole may be protected by translucent red perspex: this also acts as a light filter, which improves the legibility considerably.

As you need a large number of LEDs, shop around for these because many dealers are prepared to allow a quantity discount. Uniformity of brightness of these diodes is not so important for this application, because at the distances for which these displays are intended, differences in brightness do not show up.

Parts list

Seven-segment display:

$R_1 \dots R_7 = 100 \text{ k}$
 $R_8 \dots R_{11} (7X) = 270 \Omega$ (with 9 LEDs)
 $= 330 \Omega$ (with 8 red LEDs)
 $= 390 \Omega$ (with 8 green LEDs)

$IC_1 = 74LS248$
 $T_1 \dots T_7 = BC517$
 $C_1 = 100 \text{ n}$
 232 LEDs, 5 mm, colour as required

"1" display:

$R_1 = 47 \text{ k}$
 $R_2 = 1 \text{ M}$
 $R_3, R_4 = 470 \text{ k}$
 $R_5 \dots R_8 (2X) = 270 \Omega$
 $D_1, D_2 = 1N4148$
 $T_1 = BC517$
 $T_2 = BC547B$
 72 LEDs, 5 mm, colour as required

":" display:

$R_1, R_2 = 270 \Omega$
 18 LEDs, 5 mm, colour as required

For Components Sources See Page 9-38

3a

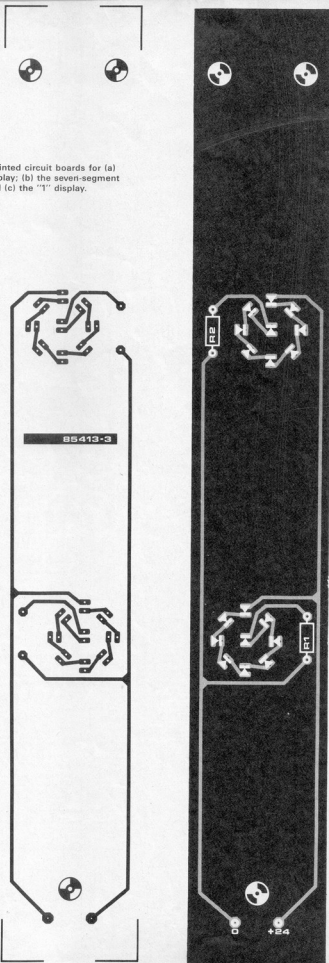
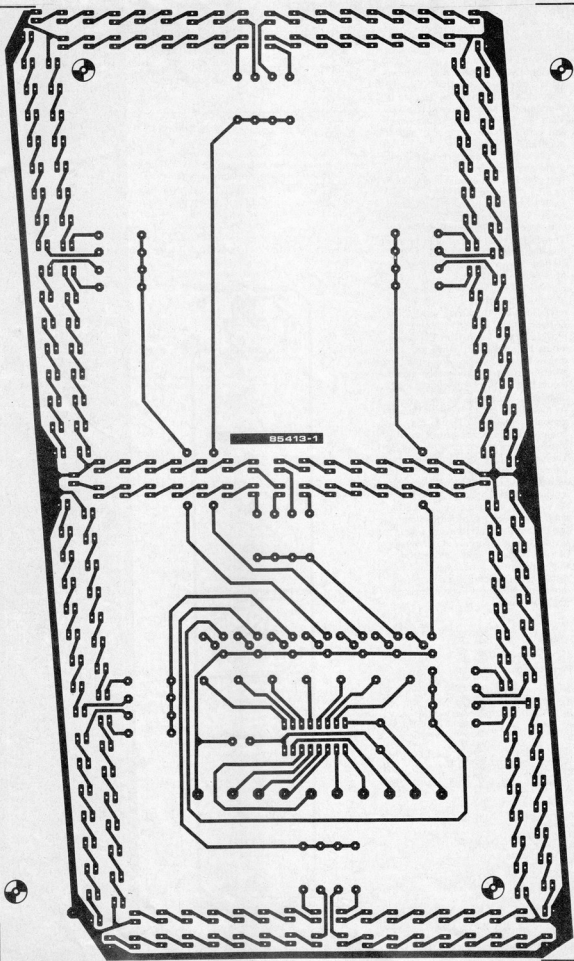
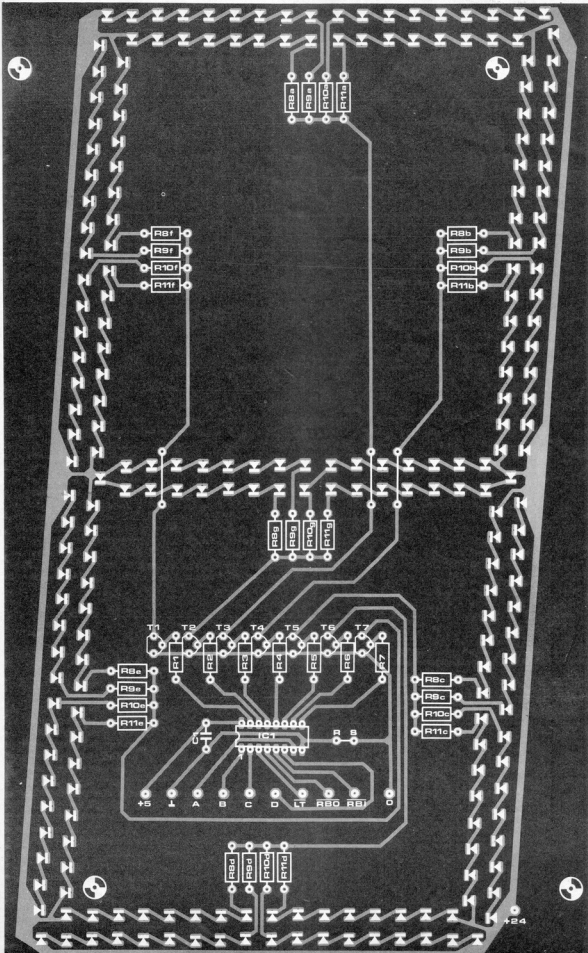


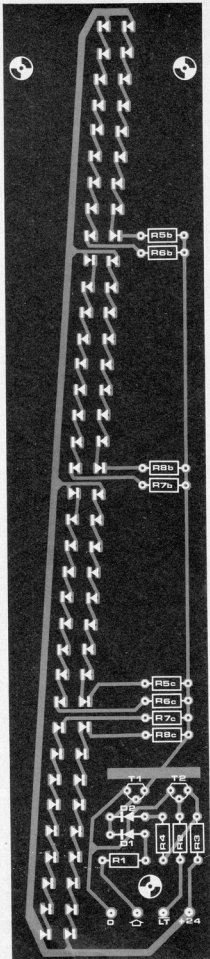
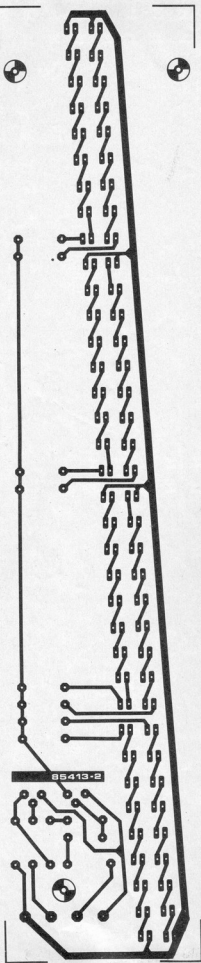
Figure 3. Printed circuit boards for (a) the ":" display; (b) the seven-segment display; and (c) the "1" display.

3b





3c





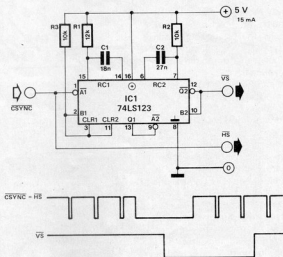
sync separator

Many monitors have separate inputs for the line (horizontal) and field synchronization pulses. If your computer only provides composite sync pulses, the circuit described here makes it possible to split the composite sync signal, CSYNC, into proper line, HS, and field, VS, pulses. It is possible to feed the CSYNC as line sync pulses direct to the monitor, which is the reason that the CSYNC input is connected direct to the HS output terminal.

To derive the field sync pulses from the composite signal, a dual retriggerable monostable type 74LS123 is needed. The first mono period is slightly longer than the distance between two line sync pulses. As the monostable is retriggered by each line sync pulse, it only resets in the absence of a line sync pulse, that is, at the onset of a blanking interval. The first monostable then triggers the second, which generates a VS pulse at its Q output. When the second mono

period has lapsed, the first monostable has already been provided with more line sync pulses, so that monostable 2 is not triggered again

until the next blanked interval. The overall result is that all line sync pulses are suppressed, while monostable 2 provides field sync pulses.



BS414



flashing light with twilight switch

The special feature of this flashing light is the optical switch, which automatically switches the light on when it gets dark, and switches it off again at dawn. This makes the light ideal as a warning light near obstructions. It may also be used for educational purposes to show the operation of transistors in conjunction with optoelectronics.

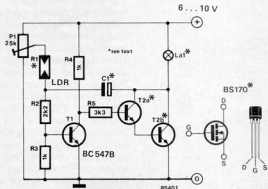
Assuming that it is light, the LDR (light dependent resistor) has a low value so that there is sufficient base

current through T_1 for the transistor to conduct. Its collector voltage is then small, so that T_2 , an n-p-n darlington, is off, and lamp L_1 stays out. When the ambient light reduces, the resistance of the LDR increases until the base current in T_1 becomes insufficient and the transistor switches off. Its collector voltage then rises, T_2 conducts, and L_1 lights. This process takes place quite quickly, because when the collector voltage of T_2 suddenly becomes nearly 0 V, this poten-

tial is immediately applied to the base of T_1 via capacitor C_1 , which really cuts off T_1 . The capacitor then charges via P_1 and the LDR that is now being illuminated by the lighted lamp. Owing to the optical feedback, the value of the LDR diminishes, the voltage across R_2 increases, and T_1 conducts again. The darlington switches off, and the lamp goes out: a new cycle has started.

The flashing frequency is primarily dependent on the value of C_1 : with 47 μF , it is rather low; reducing the capacitance increases the frequency. The BC 517 darlington may be replaced by two BC 547B transistors or a VN10KM MOSFET. The only thing that needs watching is the current through L_1 : the maximum permissible with two BC 547Bs is 100 mA; with a BC 517 it is 400 mA; and with a VN10KM it is 500 mA. Current consumption of the circuit, with lamp L_1 out, is about 6 mA at 6 V and around 10 mA at 10 V.

The light-dependent resistor may be one of the usually available types: LDR 03, 05, 07. To ensure that the optical feedback works, the LDR must be fitted near lamp L_1 . The onset of operation is set with P_1 .



BS401



model railway monitor panel

N Koerber

Many railway modellers would love to have a track monitor panel, but, unfortunately, the few commercially available types do not justify their cost. It is, however, not too difficult to make one yourself.

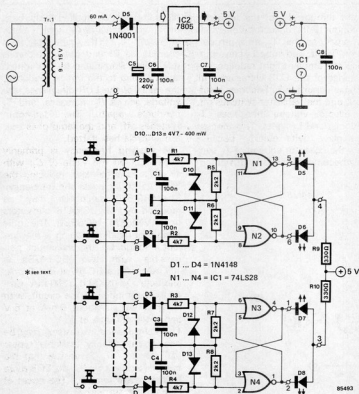
The reproducing of the track diagram and the mounting of the monitor lights on the panel can be accomplished without too much trouble. There is a problem, however, in indicating the position of turnouts and colour-light signals, because these elements are normally operated by spring-loaded switches to prevent the burning out of the solenoids. After the push-button on the control panel has been released, the supply line is no longer live and can, therefore, not be used for lighting an indicator. This problem can, fortunately, be solved by a couple of R-S bistables (NOR gate latches).

The push-button switches and solenoid coils shown in figure 1 are those already contained in the railway set-up. Note that the system is assumed to operate from a 9...15 V AC supply.

Each signal normally requires three lines: one for each of the two coils and a common line. Terminals A, B, C, and



1



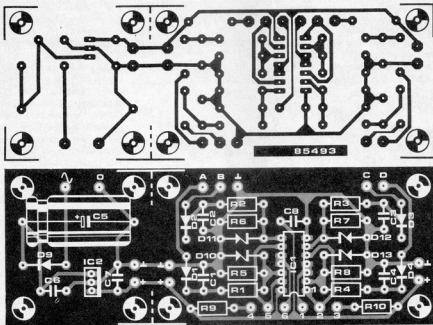
D in figure 1 are connected to the relevant outputs of the control panel. The circuit as shown is suitable for monitoring two turnouts or two colour-light signals via A-B and C-D respectively, but can be extended as required.

The voltages used to energize the coils are rectified and applied to an R-S bistable. This NOR gate latch is set or reset, depending on the nature of the input signal, and this causes the relevant LED to light. If, for instance, pin 8 of N_2 is high, pin 10 of this gate is low, and D_6 lights.

The circuit as shown has a current consumption of about 30 mA per R-S bistable branch.

Not all monitor LEDs will correctly show the position of the relevant turnout or light signal immediately upon switching on the supply. Briefly pressing one of the two push-buttons of each turnout or light signal will correct this situation.

The circuit is most conveniently built on the printed circuit board shown in figure 2. This board can accommodate two monitor channels as shown in figure 1. If more are required, these can be built on additional PCBs. The section containing C_5 , IC_2 and D_5 may be cut off subsequent boards, but if many additional PCBs are used, make sure that the power requirements are still met! The +5 V and 0 V terminals on all boards should be interconnected.



Parts list

Resistors:

R₁...R₄ = 4k7R₅...R₈ = 2k2R₉, R₁₀ = 330 Ω

Capacitors:

C₁...C₄, C₆...C₈ = 100 nC₅ = 220 μ/40 V

Semiconductors:

D₁...D₄ = 1N4148D₅...D₈ = LED (red or green, as required)D₉ = 1N4001D₁₀...D₁₃ = zener diode, 4V7/400 mWIC₁ = 74LS28IC₂ = 7805

Miscellaneous:

Tr₁ = mains transformer, 9...15 V secondary (if not already available from the existing system)

For Components Sources See Page 9-38



set pointer

Aneroïd barometers invariably have two pointers: one that is operated by the mechanics, and one that is set manually. The manually set pointer is really nothing but a mechanical memory that enables variations in barometric pressure to be ascertained.

The set pointer can, of course, be made electronic, for which a slide potentiometer is ideal. Such a pointer is not restricted to a barometer: it can also be used with a thermometer, a hygrometer, a battery that needs to be monitored; in short, with any sensor that delivers a slowly varying voltage. The circuit consists of an amplifier, IC₁, and a display stage, IC₂. The display consists of between 3 and 9 LEDs, the centre one of which, D₅, is yellow and represents the point of origin. Potentiometer P₁ can be adjusted to make this LED light. When the input voltage rises slightly, D₆ (the colour of which depends on the application) lights; when it drops, D₄ (again, the colour depends on the application, but it should be different from D₆...D₈) lights. Greater variations in input signal cause D₇...D₉

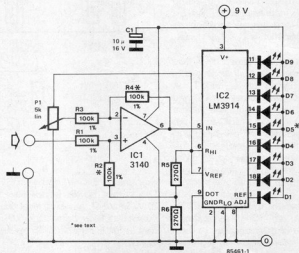
or D₃...D₀ respectively to light. It is at all times possible to adjust P₁ in a manner which causes the centre LED to light.

The potentiometer could be provided with a graduated scale to enable the input voltage to be read direct. It is

not difficult to produce such a scale. Apply voltages of 0.1 V, 0.2 V, and so on in steps of 0.1 V, and for each voltage turn P₁ till the centre LED lights. At each of the positions of P₁ so found, draw a thin line.

The sensitivity of the circuit is of some

1



import, because about 1 V is necessary at pin 5 of IC₂ to make D₁ and D₃ light. As the amplification of IC₁ is unity (R_3/R_2), about 1 V is, therefore, also needed at the input of the circuit for these LEDs to operate. Opamp IC₁ deducts the voltage at the

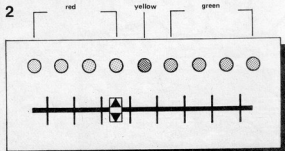
wiper of P₁ from the input signal, and adds the potential at the junction of R₅ and R₆ to the result.

Since P₁ is connected to the reference voltage (1.28 V), only this voltage can be compensated for. Strictly speaking, there is no reason

why P₁ should not be connected to the positive supply line in series with a suitable resistor. In that case, the display is only stable if the supply line is well regulated.

If the input sensitivity is too low, the values of R₄ and R₅ may be increased; note, however, that these values should always be the same.

Current consumption is determined primarily by the current through the LEDs, and that in itself is about ten times the current through R₅ and R₆. The latter current is equal to the on-chip reference voltage of 1.28 V divided by the total resistance of R₅ + R₆. The maximum current through the LEDs is about 40 mA (the current via pin 7 must not exceed 4 mA!) so that the total current does not exceed 50 mA.



85461-2

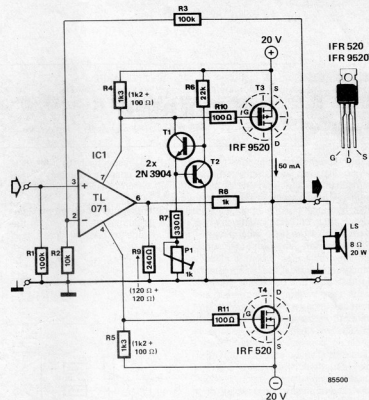


MOSFET power amplifier

The output power of an operational amplifier is often increased by a complementary emitter follower. It can also be done with a MOSFET, but it is not a good idea to connect such a device as a complementary source follower because the maximum output voltage of the opamp is then reduced appreciably by the gate-source control voltage of the MOSFET, which can be a couple of volts.

Another approach is to connect two MOSFETs as a complementary drain follower. The (alternating) output current provided by the MOSFETs is limited by the level of the supply voltages and the saturation voltages of T₃ and T₄. Resistor R₈, together with R₉, provides feedback for both the opamp and the MOSFETs. The open-loop amplification of the opamp is, therefore, increased by $(1 + R_8/R_9)$. The closed-loop amplification of the complete amplifier is $(1 + R_3/R_2)$, i.e., 11.

The current source formed by T₁ and T₂ is required for arranging the quiescent current of T₃ and T₄ at 50 mA. The values of resistors R₄ and R₅ are such that, without the current source, the voltage drop across the resistors resulting from the direct current through the opamp is not sufficient to switch on T₃ and T₄. With the current source, and depending on the setting of P₁, the voltages across R₄ and R₅ rise, which increases the quiescent current through T₃ and T₄. In view of the temperature dependence of the quiescent current, T₂ must be mounted on the common



85500

heat sink (c. 5 K/W) of the MOSFETs. The output power is not less than 20 W into 8 Ω, at which level the harmonic distortion amounts to 0.075 per cent at 100 Hz and to 0.135 per cent at 10 kHz.

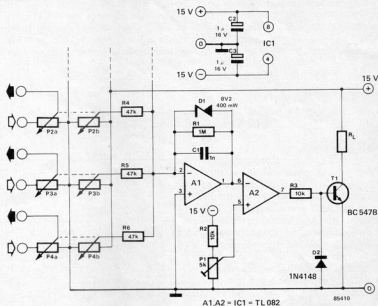
Source: *Voice coil drives using complementary power MOSFETs* by M Alexander in *Motor-Con proceedings*, April 1984



"on the air" indicator

In radio and television studios it is customary to indicate to all concerned when the microphone or camera is "on the air". This is normally done with a red light at or near the relevant camera or microphone. The circuit described here is intended as an auxiliary for a DIY mixer unit.

To make the circuit automatic in action, stereo slide potentiometers are used at the audio inputs. When one section of these potentiometers is connected to the +15 V line, the potential at the wiper of this section is a measure of the potentiometer setting. This potential is amplified in opamp A_1 , and applied to the inverting input of A_2 . The latter opamp toggles as soon as the level at its inverting input exceeds that at its +input, which has been set with preset P_1 . The slide potentiometers for this purpose are always logarithmic types, so that the voltage rise at the beginning of their travel is always pretty small. To ensure correct operation of the circuit even at these settings of the potentiometers, the gain of A_1 has been arranged fairly high, about 26 dB. Opamp A_2 also serves as a summing amplifier that monitors a row of audio inputs. If it is required that each audio input has its own monitor, the two opamps must be repeated for each input, but P_1 , of course, continues to



provide the non-inverting potential for all opamps in the A_2 position. The output of the indicator is provided by a type BC 547B transistor, which can switch up to 100 mA. This current is sufficient to light a signal lamp or light-emitting diode (LED) with bias resistor, or to drive a relay. Current consumption with the

BC 547B off amounts to not more than 10 mA. If low-resistance stereo potentiometers are used, the direct current through the "indicator section" may be too high; if that is so, it is advisable to use a dropping resistor in series with the section.

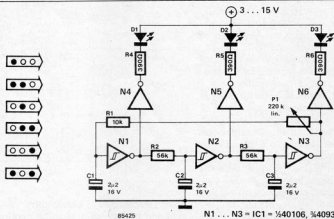


LED direction indicator

from an idea by M Miller

An LED indicator with a difference: three alternately lighting LEDs indicate a direction, for instance, in a model railway, or to an emergency exit, or to a door on badly lit stairways, and so on.

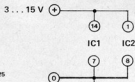
When the supply voltage is switched on, the inputs of gates $N_4 \dots N_6$ are logic 1, their outputs logic 0, and all LEDs light. One of the RC networks ($R_1 + P_1/C_1$; R_2/C_2 ; R_3/C_3) will reach the trigger threshold first. Let us assume it is $R_1 + P_1/C_1$. The output of N_1 then goes low, the output of N_4 goes high, and D_1 goes out. There is then no voltage for R_2/C_2 , the output of N_2 remains logic high, and N_5 remains logic low: D_2 then lights. Subsequently, the output of N_3 goes low, the output of N_6 becomes 1, and D_3 goes out. The logic 0 of N_3 is, after a delay in $R_1 + P_1/C_1$, again at the input of N_1 . The output of N_1



goes high, that of N_4 goes low, and D_1 lights. This process repeats itself, so that first one, then two, and then one LED again lights. At every step,

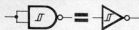
the light pattern shifts one place to give the impression of a running, flashing light. The running speed is set with P_1 .

$N1 \dots N3 = IC1 = \frac{1}{2}40106, \frac{1}{2}4093$
 $N4 \dots N6 = IC2 = \frac{1}{2}4049, \frac{1}{2}4050$



85425

It does not really matter whether you use inverting gates (4049) or non-inverting ones (4050) in the IC₂ position, as long as you connect the unused gates to the positive or



negative supply rail. The RC networks may also be modified to taste or if special effects are desired.

If you want to make the circuit even smaller, forget IC₂ and use the three remaining inverters in IC₁ as LED drivers, provided you are using a type

40106. The LED currents are then only 5...10 mA, so you have to use high output LEDs (that are bright at low currents).

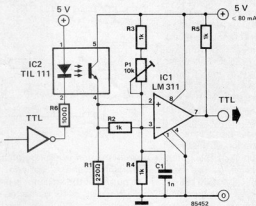
The current consumption of the circuit without LEDs and operating from 15 V is about 100 μA. With LEDs, it depends very much on the LEDs and the supply voltage: with standard LEDs and at 15 V, each LED draws up to 30 mA.



fast opto-isolator

When a computer drives external equipment, it is often required that the earths between them are electrically isolated from one another. The simplest way of effecting this is by an isolating transformer. When, however, the system works at high frequencies, it is much better to use an opto-isolator as proposed here because that is capable of following the fast data transfer.

The opto-isolator is driven via a TTL gate. The transistor in the opto-isolator drives comparator IC₁. The trigger threshold of this device is set with P₁. Low-pass filter R₂C₁ prevents spurious triggering of the comparator by noise pulses.



video amplifier for B/W television sets

It appears that the use of portable, mains operated television receivers as monitor in a computer system has become very popular. The article *use your TV receiver as a monitor* (Elektron, December 1984) described an all-embracing amplifier, but here we propose a much simpler one.

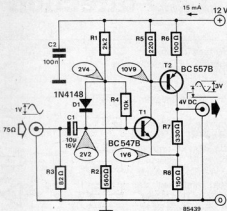
To raise the standard video signal of 1 V_{pp} to the level required by the television receiver, a preamplifier with a bandwidth of not less than 10 MHz is required. With careful construction of the present amplifier, this bandwidth is guaranteed, and should actually be of the order of close to 20 MHz. With a supply voltage of 12 V, the direct-voltage output is 4 V. If different supply voltages are used, the DC output is retained at that level by suitably altering the values of R₁ and R₂ (which form a voltage divider). However, the supply voltage should not be lower than 10 V, nor higher than 15 V. The amplification depends on the ratio R₇ : R₆; if higher amplification is needed, the value of R₇ should be

increased.

The respectable bandwidth is achieved by low value base and collector resistors: with this arrangement, even audio transistors may be used in this, essentially HF, circuit. In any case, the cut-off frequency of a BC 547 is 300 MHz, and that of a

BC 557 is 150 MHz.

The input impedance is strictly determined by R₃; its value of 82 Ω is near enough the required impedance, but if you really want to be a purist, there are 75 Ω resistors available at some stockists, or you can connect a 100 Ω resistor in parallel with a 330 Ω one.





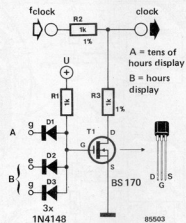
time stretcher

From an idea by S Gulikers

Anyone with a fascinating hobby must have felt at one time or another that there is not enough time available for his hobby. Any circuit that can stretch those few hours once or twice a week must, therefore, appeal to many.

The time stretcher is a small circuit that can be built into almost any digital clock and makes the hobby evening(s) last an hour longer. The three diodes, $D_1 \dots D_3$, together with R_1 , form an AND gate. D_1 is connected to segment g of the tens-of-hours display, and D_2 and D_3 to segments e and g of the hours display respectively.

When the clock shows 22.00 h, the common line of $D_1 \dots D_3$ becomes logic 1, because the three segments to which the diodes are connected are



"on". This means that T_1 conducts and the clock signal of the digital clock is divided by two. The clock

then runs at half speed only so that it will take two hours before it shows 23.00 h.

For the circuit to work correctly, it is essential that the clock signal is divided by two exactly, and this means that resistors R_2 and R_3 must be 1 per cent types. This is also the reason that a BS170 is used as the switching gate; this MOSFET has no saturation voltage. Using a normal transistor with a certain saturation voltage would not cause the clock signal to be divided by two exactly, so that the clock would be fast or slow by minutes within a few days!

The circuit as drawn is intended for common-anode displays; if it is to be used with common-cathode displays, simply reverse the connections of diodes $D_1 \dots D_3$.



twin dimmer

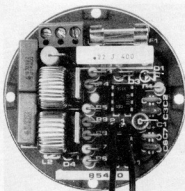
Dimmer circuits are always popular and this one offers two independent controls in one.

Control of each section of the circuit is provided by a type S576 which is an improved version of the S566. This type of IC controls the phase gating by short or long command pulses emanating from a touch pad. Pulses shorter than 60 ms are treated as noise.

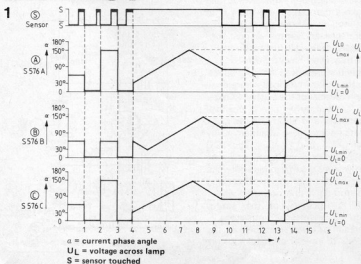
Short pulses between 60 ms and 400 ms cause the lamp to be switched on or off, depending on whether it was off or on respectively.

If the touch pad is touched for more than 400 ms, the appropriate lamp is dimmed at a certain speed. If the finger is held on the touch pad, the lamp will go out completely and will then slowly light up again: when it reaches full brightness (and the finger is still on the pad), it will begin to dim again, and so on.

The S576 is available in three versions: A, B, and C. With the A and C versions, the lamp is always switched on or off half-way between maximum and minimum brightness, and it first attains maximum brightness before it can be dimmed. The B version is interesting in that it remembers the last brightness level, so that the lamp is always switched on or off at the last brightness setting. These various possibilities are summarized in figure 1.



The circuit of the twin dimmer is shown in figure 2. Power for the ICs is provided via R_2 , C_4 , D_1 , and D_3 . The supply is smoothed by C_1 . Capacitors C_3 and C_6 determine the speed with which the lamps dim or get brighter. The twin dimmer is best built onto the printed circuit board shown in figure 3. This board is intended to be fitted into a standard round junction box. Because of this, it is, of course, important that the components used are of the correct size as shown on the board.

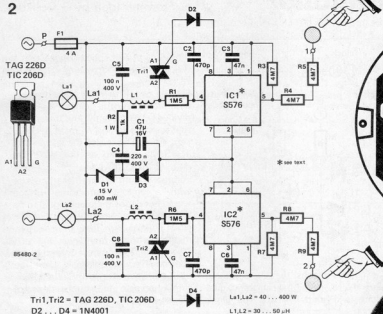


The board is connected to the lighting system via three terminals: L to the live wire, and S_1 and S_2 to the

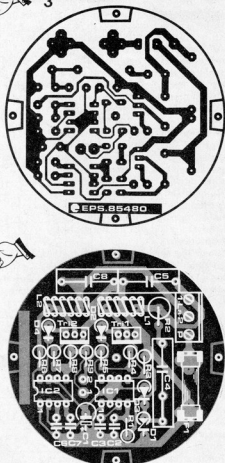
switching wires of the lamps. The junction of the lamps is (already) connected to neutral.

Note that the dimmer cannot be used with neon tubes.

2



3



Parts list

Resistors:

- R₁, R₆ = 1M5
- R₂ = 1 k/1 W
- R₃...R₅, R₇...R₉ = 4M7

Capacitors:

- C₁ = 47 μ /16 V
- C₂, C₇ = 470 p
- C₃, C₆ = 47 n ceramic
- C₄ = 220 n/400 V
- C₅, C₈ = 100 n/400 V

Semiconductors:

- D₁ = zener diode 15 V/400 mW
- D₂... D₄ = 1N4001
- IC₁, IC₂ = S576 (see text for which version)
- Tri₁, Tri₂ = TAG226D or TIC206D

Miscellaneous:

- L₁, L₂ = 30...50 μ H/2 A
- F₁ = zener action and associated PCB holder
- 1 three-way ceramic terminal block (5 A)
- PCB 85480

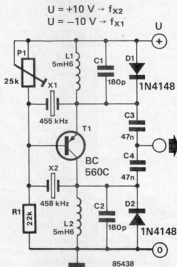
For Components Sources See Page 9-38



two-frequency oscillator

Not so long ago, when semiconductors were still quite expensive, it paid to make a transistor serve more than one function. Although this is no longer necessary because of cost considerations, it is still fun to do so — and it may even have its uses!

The circuit presented here is an LC oscillator that changes frequency through reversal of the supply voltage. When the supply voltage is positive, D₁ conducts and short-circuits L₁C₁. Oscillations are then maintained by crystal XL₂ and L₂C₂. The DC operating point is set by P₁ in a way which ensures a compromise between faultless starting of the oscillator and low distortion of the output signal. When the polarity of the supply voltage is reversed, transistor T₁ operates in its inverted mode, i.e., the functions of emitter and collector are



interchanged. This means that the amplification is reduced, but, of course, an oscillator needs an amplification of only just above unity to operate. Crystal XL₂ and L₂C₂ are effectively cut out by D₂, and the frequency is now determined by crystal XL₁ and L₁C₁.

The circuit lends itself, for instance, for use as BFO switched between USB and LSB. The crystals may have values of up to 1 MHz. Current consumption in either mode does not exceed 45 mA.

From an idea in the *Master Handbook of 1001 Electronic Circuits*.



automatic car alarm

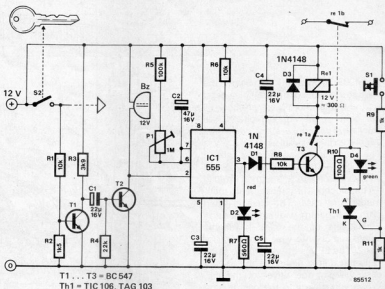
H Gulitz

Even the best car alarm is useless if you forget to set it upon leaving your car, whence this circuit.

The relay has a make and a break contact: the former is necessary to delay the switching in of the alarm after you have got out of your car, and the latter serves to switch on the car alarm proper.

Immediately on re-entering your car, you must press the hidden switch, S_1 . This causes silicon-controlled rectifier Th_1 to conduct so that the relay is energized. At the same time, the green LED lights to indicate that the alarm is switched off.

As soon as the ignition is switched off, T_1 is off, T_2 is on, and the buzzer sounds. At the same time, monostable IC_1 is triggered, which causes T_3 to conduct and the red LED to light. The silicon-controlled rectifier is then off, and D_4 is reverse biased, but the relay remains energized via its make contact for a short time, preset by P_1 . As soon as this time has lapsed, the relay returns to its



quiescent state, and the alarm is set via the break contact. The delay time

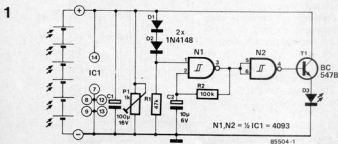
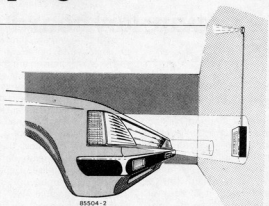
can be set to a maximum of about 1 minute.

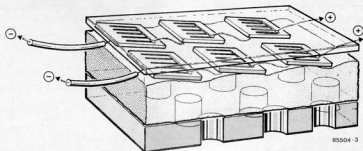


garage stop light

A novel use of solar cells makes positioning your car in the garage rather easier than old tyres, a mirror, or a chalk mark.

The six solar cells in figure 1 serve as power supply and as proximity sensor. They are commercially available at relative low cost. The voltage developed across potentiometer P_1 is mainly dependent on the intensity of the light falling onto the cells. The circuit is only actuated when the main beam of one of the car's headlights shines direct onto the cells from a distance of about 200 mm (8 inches). The distance can be varied somewhat with P_1 .





the 4093 is always 1.2 V below the voltage developed by the solar cells. As the trip level of N_1 lies at about 50 per cent of the supply voltage, the oscillator will only start when the supply voltage is higher than 2.4 V.

The circuit, including the solar cells, is best constructed on a small veroboard as shown in figure 3, and then fitted in a translucent or transparent handmade fibre case. The case is fitted onto the garage wall in a position where one of the car's headlights shines direct onto it as shown in figure 2. The LED is fitted onto the same wall, but a little higher so that it is in easy view of the driver of the car. When you drive into the garage, you must, of course, remember to switch on the main beam of your headlights! A descriptive article on the operation and use of solar cells appeared in the July 1985 issue of *Elektron: solar battery*.



Perhaps now you understand why I have been nagging you to fit that Elekton stop light in the garage!



twain keyboard for Apple II

W Arends and H G Scholz

The keyboard supplied with computers is for many applications not the *ne plus ultra* it is claimed to be. Unfortunately, deficiencies normally do not become apparent until the machine has been in practical use for a while. Retailers have long since realized this and often stock improved keyboards that are fully compatible with the computer in question. It is, however, not always clear how the new keyboard can be attached to the computer. One possibility is, of course, to open the computer, remove the existing keyboard, install the new keyboard, and put the computer together again. It is, however, much better to use the solution suggested here, which is aimed at the Apple II and compatible machines.

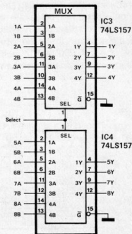
The accompanying circuit makes it possible to connect the additional keyboard in parallel with the existing one. Basically, it is just an electronic switch-over unit, designated MUX in the diagram.

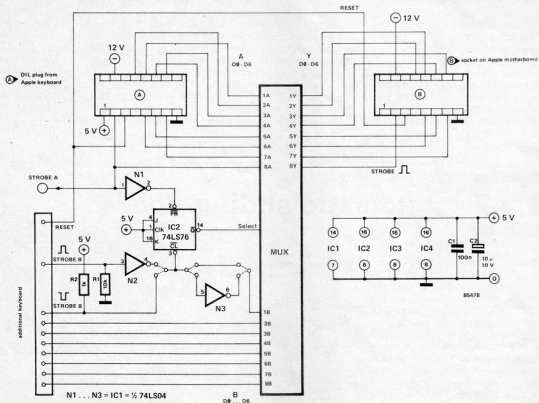
Both keyboards are connected to the input of MUX by their data lines. Which keyboard data are applied to the computer is from now on determined by MUX.

When a key is struck, the keyboard does not only generate data bits, but also a strobe pulse. Depending on whether the strobe pulse emanates from the original or from the additional keyboard, the \bar{Q} output (pin 14) of bistable IC₂ is set or reset. This pulse, therefore, serves as a select signal for the MUX. The electronic switch consists of two types 74LS157 ICs. Each of these ICs contains four 2-to-1 multiplexers, so that all eight input data are available at the output. If the select input of both ICs is logic 0, outputs 1Y...8Y contain the data present at inputs 1A...8A. If, however, the input to the ICs is logic 1, the data from 1B...8B is available at 1Y...8Y.

The Apple II requires a positive strobe pulse, and inverts N_2 and N_3 as,

therefore, provided to ensure that this condition is met whatever the strobe pulse from the additional keyboard.

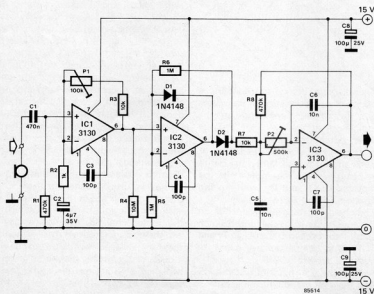




blow that synthesizer!

Circuits for generating electronic music are usually controlled by key switches. Not only do keyboards offer the simplest technical solution for producing fast changing, reproducible tones over a wide frequency range, but they also enjoy tremendous

popularity because they are considered to be easier to learn to play than string or wind instruments. Because of that, we have not tried to create an electronic oboe, flute, or clarinet with the present circuit. In any case, the technical intricacies associ-



ated with such instruments would make their electrophonic counterpart prohibitively expensive.

So, what we have got here is the relatively simple facility of converting breath power into a proportional analogue voltage with which the volume of a music synthesizer can be controlled; the tones remain controlled by the keyboard switches. No doubt, many of you, ingenious readers, will be able to think of various other applications of the converter. The circuit does not operate direct from the exhaled breath, but from the noise generated by this. A thin, flex-

ible tube, to which a mouthpiece may be attached, leads into a closed box, in which not only the circuit, but also an inexpensive microphone have been fitted as shown.

The noise received by the microphone is amplified in IC₁, the gain of which can be adjusted with P₁, and subsequently rectified by IC₂-D₁-D₂. An active low-pass filter removes most of

the ripple from the output voltage.

To keep the circuit as simple as possible, we have opted for a compromise between input sensitivity and output ripple: the relation between these two properties can be adjusted with P₂. If you have an oscilloscope with slow sweep, calibration of the converter should present no problems.

First, adjust the value of P₁ so that

the output voltage with hard blowing into the tube just does not cause full drive (dependent on the sensitivity of the following instrument).

Second, adjust P₂ so that the output signal is relatively free of ripple, while the converter still reacts to normal breathing. A steeper filter would have been better here, but that would have increased the cost.



automatic sliding door

Nobody pays much attention to automatically opening and closing sliding doors nowadays. In view of the complex mechanics involved, not too many people have so far attempted to fit an automatic sliding door in their living room. If you are happy with a relatively slow movement, such a door can, however, easily be realized with the aid of a DC motor and a small electronic control unit.

The basic mechanical construction of the automatic door is shown in figure 1. A suitable length of stranded nylon wire is attached to the left- and right-hand sides of the door and strung across four nylon roller guides as shown. The wire is attached to the spindle of a DC motor, the rotational direction of which depends on its polarity. Such motors are available in variety in many model building shops or from electrical suppliers, and should be suitable for operation from 6...18 V.

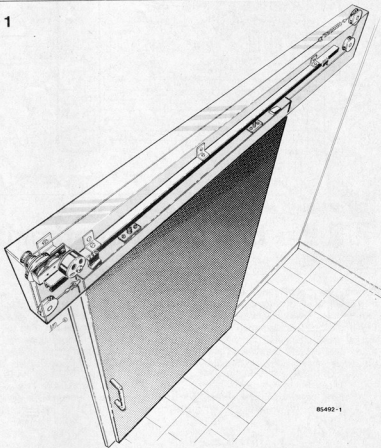
It will be sufficient to loop the nylon wire a couple of times round the motor spindle. Correct tension is obtained by incorporating a tensile spring in the wire as, for instance, shown in figure 1.

A small push button switch is fitted in the left- and right-hand door frames so that when the door is fully open or closed, a switch contact is closed.

You also need a light barrier or similar device that transmits a positive pulse of suitable length on the approach of a person. Such devices have been published in *Elektron* before, and there is also one elsewhere in this issue.



1

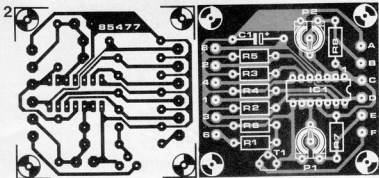


The diagram in figure 2 contains a bridge circuit, consisting of transistors T₁...T₄ which, depending on the logic level at the bases of T₁-T₃ or T₂-T₄, determines whether the motor is at standstill, rotates clockwise, or turns anti-clockwise. When the circuit is being tested, the motor may be replaced by D₁ and D₂ (with limiting resistors R₈ and R₉ respectively).

The choice of transistors depends on the current drawn by the motor, which should not exceed 500 mA. T₁-T₃ and T₂-T₄ form complementary pairs, for instance, BD239-BD240.

A short pulse at pin 6 of bistable FF₁ sets the door in motion: the first time,

it may be necessary to reverse the connections to the motor! When the door is fully open, it touches switch S₂. It does not matter whether it is just a touch or whether the door keeps the switch depressed: the motor stands still for a short time, which is adjustable with P₁, and then rotates in the opposite direction so that the door closes. If, while the door is closing, the light barrier is actuated, the motor changes direction again, and the operation repeats itself. When the door is closed, switch S₁ provides a pulse which causes the motor to be switched off until the next time the light barrier is actuated.



Parts list

- R₁ = 47 k
- R₂...R₅ = 100 k
- R₆ = 10 k
- R₇, R₈ = 22 k
- P₁, P₂ = preset potentiometer, 50 k

Capacitor:
C₁ = 10 μ/10 V

Semiconductors:

- T₁ = BC547B
- IC₁ = 4066

Miscellaneous:

- S₁...S₅ = contacts in joystick

For Components Sources See Page 9-38

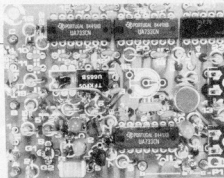
program, and adjust the potentiometers so that the two numbers on

the screen are as near as possible 32768.

Note that the printed circuit board in figure 2 is not available ready made.



GHz prescaler



In the 1.2 GHz input stage (February 1985) for the microprocessor-controlled frequency counter, we used an SB8755 prescaler in the IC₇ position. This IC, which divides the 100...1200 MHz signal at input C by 512, is perfect for the purpose, but is rather expensive. Just recently, another prescaler, which is much cheaper and more sensitive, has come onto the market: the U665B from Telefunken.

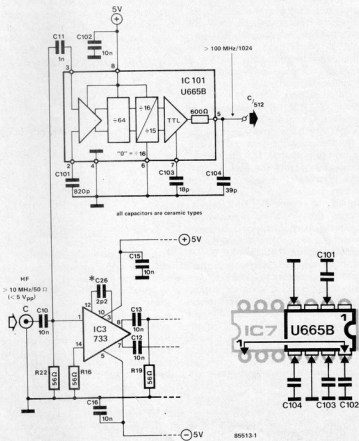
The U665B is a ÷1024 prescaler with integral pre-amplifier. Its sensitivity is better than 10 mV_{rms} for frequencies between 80 MHz and 900 MHz. It is fully usable up to 1200 MHz, but its sensitivity drops to about 30...40 mV_{rms} at that frequency.

To fit the U665B onto the PCB, first remove existing IC₇, IC₈, and P₃. No other components should be removed because, although they may look superfluous, they are needed for the interconnection between the component and track sides of the board.

The new IC is fitted so that its pin 1 coincides with pin 8 of the previous IC₇. Next, solder capacitors C₁₀₁, C₁₀₂, C₁₀₃, and C₁₀₄ direct to the relevant pins of the new IC and to the earth plane. Then, solder pins 4 and 6 direct to the earth plane and place a wire link between pin 8 of the U665B and the hole where pin 1 of IC₇ used to be (see drawing). Finally, solder a wire link between the holes where pins 1 and 11 of IC₈ used to be.

So much for the hardware; now something about the software. The U665B divides the input frequency by 1024, while IC₇+IC₈ divided by only 512. This difference means that one byte in the EPROM must be altered: address \$627 reads \$09; this should be amended to \$0A.

Finally, note that the U665B may not yet be available everywhere.



Digi-Course

Chapter 4

Solving an old puzzle with electronics.

Circuits based on NAND and NOR gates were discussed in the last chapter. The truth tables make the functioning of these gates very clear and easy to understand, by relating every input combination to a unique output state.

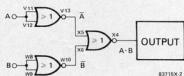


A	B	NAND NOR	
		$\overline{A \cdot B}$	$\overline{A + B}$
0	0	1	1
0	1	1	0
1	0	1	0
1	1	0	0

In the last chapter, we had given two problems for you to solve. Let us first discuss their solutions. The first problem was to construct a circuit functioning as an AND gate using only NOR gates. The truth table is given below.

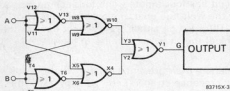
A	B	NOR AND	
		$\overline{\overline{A + B}}$	$\overline{\overline{A \cdot B}}$
0	0	1	0
0	1	0	0
1	0	0	0
1	1	0	1

Similar to the OR circuit built using NAND gates, here also the input states must be inverted. The inverters are obtained by using NOR gates with shorted inputs.



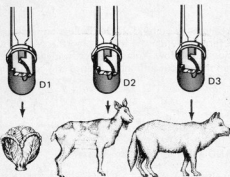
A	B	\overline{A}	\overline{B}	$\overline{\overline{A + B}}$	$\overline{\overline{A \cdot B}} = A \cdot B$
0	0	1	1	1	0
0	1	1	0	1	0
1	0	0	1	1	0
1	1	0	0	0	1

The second problem was to find the function represented by the following circuit.



As we do not have five NOR gates on our Digilex Board, one of the inverters can be replaced by an inverter obtained from a NAND gate. The solution is very simple. By connecting the circuit on the Digilex Board and studying the input-output relations we know that the output indicates whether both the inputs are equal. The function is known as Inclusive-OR or simply EXNOR. The complete truth table is given below for those interested in the theoretical aspect of the circuit.

A	B	\overline{A} (V13)	\overline{B} (T6)	$\overline{\overline{A + B}}$ (W10)	$\overline{\overline{A + B}}$ (X4)	Y1
0	0	1	1	0	0	1
0	1	1	0	0	1	0
1	0	0	1	1	0	0
1	1	0	0	0	0	1



Wolf, Goat and Cabbage.

The old puzzle about the wolf, goat and cabbage can be solved with the help of electronics. This is how the story goes: A farmer comes with a wolf, a goat and a cabbage to the bank of river. He has to cross the river in a boat. But there is a problem - he can take only one object with him in the boat at a time. How does he cross the river, without the wolf gobbling up the goat or the goat gobbling up the cabbage?

We can connect the circuit on our Digilex Board to solve the puzzle. We need all the three ICs for this purpose; and all the eight indicators. For solving the puzzle, we need indication for the presence of the animals and cabbage on the left and right banks of the river, and of course - indication if there is a risk on any of the two banks, that either the wolf gobbles up the goat or the goat gobbles up the cabbage.

Definitions

At the beginning, we must define certain things - because the gates can only recognise only two states "0" and "1" represented by 0V and 5V.



Our circuit has four inputs - one for each participant, namely the wolf, the goat, the cabbage and the farmer. They can be either on the Right bank or the Left bank of the river, so it's easy to represent by "0" or "1".

Let us denote their presence on the "Right" bank by "0" and presence on the "Left" bank by "1". The circuit can be connected in such a manner that LED indicators D1, D2, D3 will glow when cabbage, goat and wolf are present on Left bank and D6, D7, D8 will glow when they are present on the Right bank. When the Digilex Board is placed on the top edge of the magazine, the symbols show the meaning of LEDs. LEDs D4 and D5 glow if there is risk on Left or Right bank. The inputs are provided with four connectors, at the input terminals:

- K13 for cabbage (C)
- L10 for goat (G)
- M4 for wolf (W)
- N2 for farmer (F)

Connecting the circuit.

Connect the indicators first. The LEDs on Left side must glow when the corresponding inputs are "1". Hence they are connected directly as follows:

- A - K13
- B - L10
- C - M4

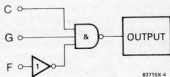
As we have only eight LEDs, no indication is provided for the farmer. When the inputs are "0", the LEDs on right side must glow. This requires an inverter between the output and input. Hence the connections are:

- F - K11
- G - L8
- H - M6

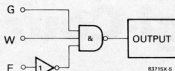
(k12-K13, L9-L10, M4-M5, N1-N2 are shorted so that the NAND gates function as inverters.)

The remaining circuit must be connected in such a way that LED D4 glows when there is risk on Left bank and LED D5 glows when there is risk on the right bank. The risk condition is present when either the cabbage and goat or the goat and wolf are present on the same bank without the presence of farmer on the bank.

Let us begin with the left bank. LED D4 must glow when cabbage and goat are on left bank and farmer is on right bank, and it must also glow when goat and wolf are present on left bank and farmer is on right bank.



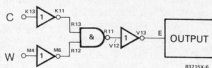
C="1", G="1", F="0"



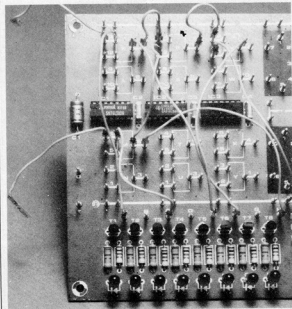
G="1", W="1", F="0"

Both these circuits require a triple input nand gate, which is not available on the Digilex Board. Hence we must look for another circuit configuration. Rather than proceeding mathematically, we want to solve the problem as a game. Mathematical approach will also require detailed knowledge of Boolean Algebra.

Let us tackle the problem from the other side. Instead of looking for combinations when there is risk, let us look for the conditions when there is no risk. This step is not as arbitrary as it may appear. In fact we need an inversion at the end because we have only NAND and NOR gates available on the Digilex Board. The goat plays a decisive role, as it can eat the cabbage or can be eaten on by the wolf. Let us start with the left bank. There can be no risk on the left bank when cabbage and wolf are both on the right bank. This is represented by the following circuit.



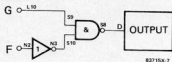
"1" when C="0" and W="0"



The connections are as follows:

- K11 - R13
- M6 - R12
- R11 - V12
- V11 - 0
- V13 - E (For testing the output)

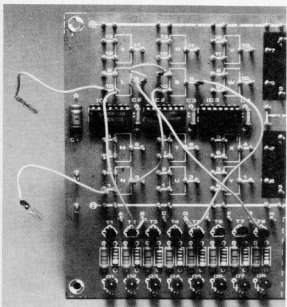
Because of the size of boat the farmer cannot leave the goat on one bank alone and take cabbage and wolf together with him to the other bank. This means that there can be risk on the left bank when goat is present but farmer is not present. This can be represented by the following circuit.



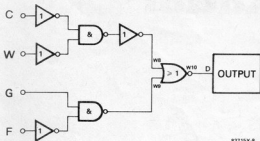
"1" except when G="1" and F="0"

The connections are as follows:

- L10 - S9 (change over B - L10 to B - S9)
- N3 - S10
- S8 - D (for testing the output).



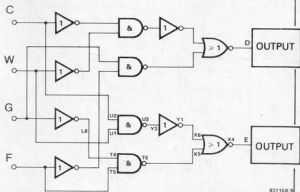
But these circuits let us know when there is no risk on the left bank. We need an indicator to glow when there is risk on that bank. So the outputs of these two individual circuits are placed on the inputs of a NOR gate and the output of the NOR gate is connected to the indicator circuit D. This makes the LED D4 glow when there is risk on the left bank.



The connections are as follows:

- Remove S8 from D and V13 from E. and connect
- S8 - W9
- V13 - W8
- W10 - D.

Thus we have got a circuit which indicates risk on the left bank. A circuit to indicate risk on the right bank is now very simple. The point to note here is that a logic "0" state at the input represents presence on the right bank.



The connections are as follows:

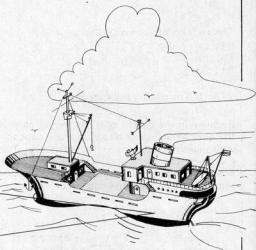
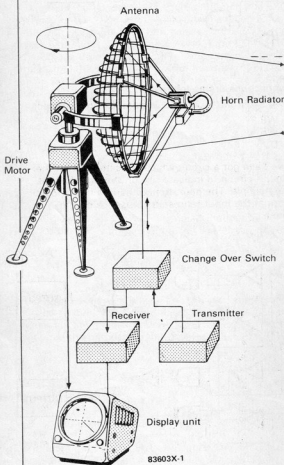
- K13 - U2 (previously reverse K13-A to A-U2)
- M4 - U1 (previously reverse M4-C to U1-C)
- U3 - Y3
- Y2 - 0
- Y1 - X6
- T6 - X5
- X4 - E

The circuit makes the LED D5 glow when there is risk on right bank.

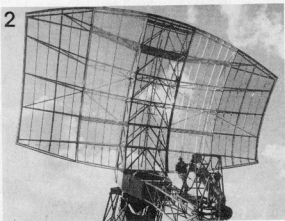
Now, you are ready to solve the puzzle on the Digilex-board!

Note: Do not leave any inputs in open states, connect them either to + or 0.

Radar



2



Radar Antenna

Everyone remembers how the natural phenomenon of ECHO fascinated us in childhood, RADAR also functions using the principle of ECHO.

A special transmitter transmits a radio signal which is reflected, when it hits an obstacle like a ship, a plane, a car or even a mountain. The returning signal is received by a receiver. The time taken by the signal to return tells us the distance between the Radar and the obstacle. The frequency of the radio signal used by Radar is between 0.3 GHz and 30 GHz. (1 GHz = 1 Billion oscillations per second). Since the radio signal can also travel at night and under fog, Radar can "see" even under these conditions which are impervious for the human eye.

Two of the most well-known possibilities for the application of Radar are:

1. Radar for locating ships, aeroplanes, coasts etc.
2. Radar for monitoring speed in road traffic.

This article deals only with the first type- Locating Radar.

Radar can be recognised easily from the large rotating antenna. One such antenna is shown in figure 2. The Radar antenna transmits short pulses of radio signal. The construction of the antenna ensures that the signal is beamed in only one direction. The receiver then "listens" for the echo in the same direction, after every pulse is sent. If the beamed signal pulse encounters an obstacle, the signal is echoed back and received by the receiver. The Radar evaluates the time lag between the transmitted pulse and the received pulse. The longer the obstacle distance, the greater is the time lag.

The Radar antenna continuously rotates around its axis, thus covering all directions in each rotation. The screen of the receiver is also circular in shape and the center of the screen represents the location of the



Antenna and Display unit of a small Radar equipment

Radar station. The complete screen can be considered as the map of the area being covered by the Radar beam. The Radar signal pulse can be thought of as an invisible point moving on the screen from the center to the border of the screen. As soon as an echo is received by the receiver it makes this invisible point visible momentarily and the screen is illuminated at this position which corresponds to the location of the obstacle from which the pulse was echoed back. As the antenna is rotated uniformly at 20 to 30 rotations per minute, the illuminated spot on the screen also indicates the exact direction of the obstacle with respect to the Radar position.

The pulses are sent out at the rate of 5000 per second, and thus forming an invisible line on the screen between the center and the border which continuously points in the same direction at which the antenna faces. Thus this invisible line scans the complete screen during each revolution of the antenna. The point representing the obstacle location is illuminated during each rotation of the antenna. If the obstacle happens to be moving, the movement is also recorded by the illuminated spot on the screen.

As the fixed Radar station locates the moving obstacles, like ships and aeroplanes etc., conversely ships and aeroplanes with built-in Radar systems can determine their own location with respect to a fixed point, or various features of the landscape around them. (Mountains, Coastal strips etc.) These mobile Radar equipments consist only of two units — the antenna and the screen, as shown in figure 3.

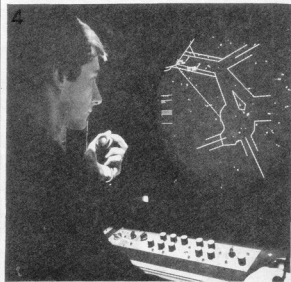
As against this, the modern Radar systems, for instance the control apparatus of flight safety, are considerably more elaborate and complex, and they are mostly computer controlled.

The computer collects and processes the information from the Radar receiver before feeding it to the screen. The illuminated spot does not fade out during each rotation and the computer can superimpose a map with important information on the screen.

A secondary Radar equipment shown in figure 4 can even identify individual aeroplanes. For this the plane must have a transponder on board, which receives the Radar signal and transmits its own signal containing a characteristic features. The secondary Radar equipment of the flight controller receives the transponder signal, decodes the characteristic features code and shows it on the screen.

From this the traffic controller knows, as to which illuminated spot corresponds to which aeroplane. Without this type of computer-controlled Radar equipment it would be impossible to manage the monitoring of the modern air traffic at large Airports.

Radar screen at the Air Traffic Control



4.5V Battery Eliminator

A simple battery eliminator circuit for 4.5V output is presented here which will be quite useful for the hobbyist.

The circuit must meet two basic requirements.

1. To convert the mains supply voltage of 230 V AC to 4.5 V AC.
2. To rectify the AC voltage.

The first requirement is met by the transformer.

The mains supply cord brings the mains voltage of 230 V to the transformer, through a fuse Si and the main switch S1. S1 is used to switch the power ON or OFF, where as the fuse Si serves to interrupt the supply of current to the transformer in case of a short circuit. As soon as a short circuit develops, the current through the fuse shoots up, the fuse wire melts and the supply is cut off.

The neon lamp La glows when the mains voltage is available across the primary winding of the transformer.

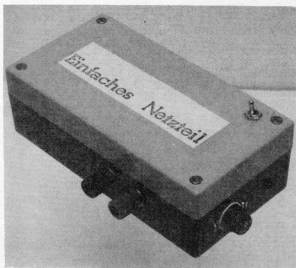
When the mains voltage of 230 V AC is present across the primary, an alternating voltage of 4.5 V induced across the secondary winding. This 4.5V AC is supplied to the rectifier bridge, made of four diodes. A diode allows current flow only in one direction, as if it was a closed switch. (Figure 2) If the voltage changes polarity, the diode behaves like an open switch and blocks current flow. (Figure 3).

Now let us see the effect of having four diodes in bridge connection.

At first let the plus pole be on the top of the bridge input. Diodes D2 and D3 behave as closed switches. Diodes D1 and D4 behave as open switches. (see figures 2 and 3). This combination gives a plus pole at the top even at the output of the bridge.

As the voltage supplied at the input of the bridge is an alternating voltage, the poles will reverse after one hundredth of a second and now at the input of the bridge we have minus pole at the top. (Figure 5).

As the voltage polarity has reversed, diodes D2 and D3 behave as open switches and diode D1 and D4



behave as closed switches. Even this combination gives rise to plus pole at the top on the output side which means that we have a direct voltage at the output of the bridge.

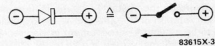
2



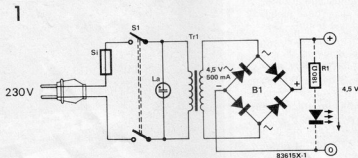
This direct voltage at the output is however not comparable to the battery voltage. Even though the direction of voltage is steady, the value is not. This gives rise to a humming noise if an audio apparatus like a radio is connected across this power supply. An electrolytic condenser of 1000 μF /16V must be connected across the output terminals of the bridge circuit to get over this problems.

(Remember the polarity of the Electrolytic condenser)

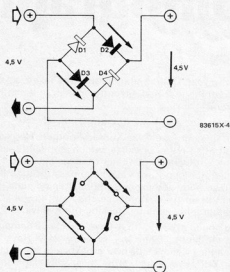
3



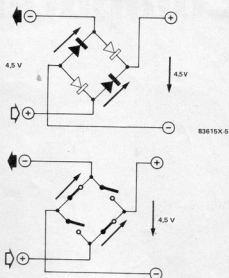
An LED in series with a 180 Ω is shown in figure 1 across the output. This can serve as the "Power ON" indication instead of the neon lamp La.



4



5



Component List

- B1 = Rectifier bridge
- Tr1 = 4.5V/500mA Transformer
- La = Neon Lamp (230V)
- Si = 200mA Fuse
- S1 = Double pole switch 230/1.5A

Other components:

- 1 Mains cord with 3 pin plug.
- 1 Enclosure Box.
- 2 Sockets (Red and Black)
- 1 Fuse holder and fuse

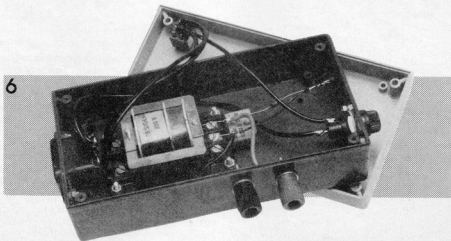
Construction Details:

Assembly of the circuit can be simplified by using plastic box.

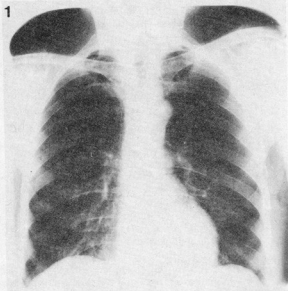
While four leads of the rectifier bridge are directly soldered. Input pair to the secondary of transformer and the output pair to the + and - sockets.

Double check all connections and polarities before switching ON. If all connections are correct and components good, circuit should work at the first attempt.

Figure 6 shows a laboratory prototype.



Computer Tomography



In the year 1895, a photograph was taken, showing something that had never been seen in a photograph before.

The Bones of a living human hand!

The photographer was Konrad Rontgen. He proved with this that a ray exists, which is indeed related to light, but works much finer than visible light. This ray, called Rontgen Ray (X-Ray) can pass through the human body and expose a photographic plate. Bones and thicker tissues produce shadows on the photographic plate by blocking the X-Rays.

Prolonged exposure to X-Rays can cause damage to the human body. Even the inventor of X-Rays himself became a victim of the over exposure. In spite of this risk, the X-Rays are one of the most important diagnostic tools.

The conventional X-Ray process has two main disadvantages:

1. Organs lying one over the other are not clearly distinguished in the X-Ray photograph, as their images overlap each other. For example, during a scan of the lungs, the ribs, the lungs the vertebral column and heart are simultaneously photographed on the plate.
2. Many organs block the X-Rays with equal intensity and appear on the plate as same shade of grey.

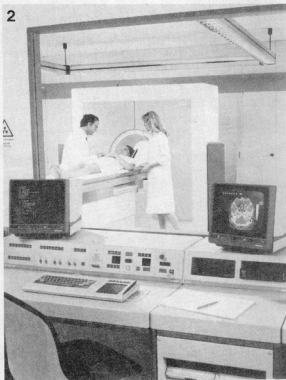
A simple method for overcoming this problem is to take the photographs from two different directions so that the X-Ray specialist can accurately localise the conspicuous tissue, for instance a tumour.

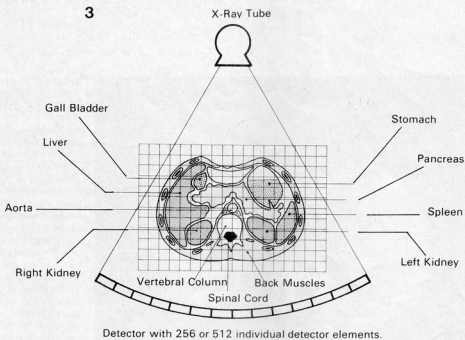
Unfortunately even in the second photograph the images do overlap in another direction, and the process still does not offer a totally clear picture. However this gives us an important clue that each additional photograph contributes additional useful information. This itself is the basic principle of the Tomograph.

Tomograph

The usual X-Ray equipment transmits one cone of rays, with which the entire surface of the photographic plate is exposed. The X-Ray tube of the tomography equipment transmits the rays only in one plane. (see figure 3). If these rays were used to expose a photographic plate as before, they would form only a thin line image on the plate. These rays are taken up by a row of X-Ray sensitive electronic detectors, which measure the intensity of the rays reaching them. An electrical signal corresponding to the intensity is sent to the computer by each individual detector.

For preparing a tomograph, the total equipment, including the X-Ray apparatus and the row of detectors, rotates once around the patient. Figure 4 shows that the source of rays and the array of detectors must rotate in the same plane. The X-Ray





apparatus emits the rays at short intervals, so that during a full rotation a number of sets of values are collected. Because of the pulsed radiation of the rays, effect of the rays on the patient is kept within limits. The computer collects all the measured values and puts together a picture from them, which shows the cross section of the body in the plane of rotation. Figure 5 shows a typical tomograph. The scan level is at the height of kidneys. Even a layman can recognise the liver on the left side, vertebral column in the middle and the two kidneys next to it. (The tomograph shows the section from below.)

Since every point is scanned several times, this apparatus can also distinguish between less differentiated tissue types, which appear equally grey on the conventional X-Ray plate.

The Computer

The computer carries out the following functions:

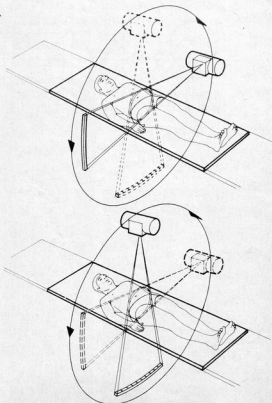
- Collecting the detector values.
- Composing a picture from the collected values.
- Controlling the operation of the complete equipment.

How the computer produces the picture from the measured values can be explained with a simple example. Figure 6 shows a cross-section, which consists of nine squares, some are white and others black. Like the organs of the body the squares are not seen from outside. A simplified tomograph should find out the distribution of the squares. At first the structure is scanned from the top. The detectors lying below detect the shadows of the squares. From this the layout of the elements cannot be recognised. The second photograph is taken from the side. Even this measurement (b) does not allow us to draw any conclusion about the distribution of elements. The third photograph taken along the diagonal shows the presence of three black squares along the diagonal. This corresponds to the third possibility among the five possibilities for the distribution presented by the

first two photographs (see figure 6c).

It is not just a coincidence that in our example three measurements were necessary. From three tests with three values each, we obtained nine observations which are sufficient to establish the distribution of nine squares.

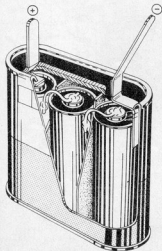
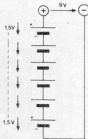
4



Batteries in series connection

We have already seen that the standard voltage available from a Zinc-Carbon cell is 1.5 V. However we also know that batteries with even higher voltages are available, for example, the 9V battery, which is most popularly known.

1



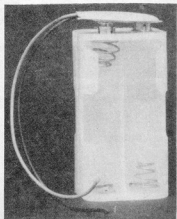
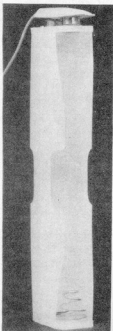
8360EX-1

The second illustration in figure 1 discloses the secret of this higher voltage available from a single battery. Six individual 1.5 V cells are packed inside the casing to give 9 V output. Some manufacturers also offer battery packs with 3V or 4.5V output. First and the third illustrations in figure 1 show the details of these battery packs.

This principle of increasing the total output voltage is known to everyone who has a torch. More than one battery cells are inserted into the torch casing in such a way that plus pole of every cell has a connection with minus pole of the previous cell.

This arrangement functions in a way similar to that of a train having two engines. Naturally, both the engines must pull in the same direction. In case of batteries, the voltages must pull in the same direction. This "direction of pull" of the cells is shown in the illustrations by arrows. Whenever batteries or other electronic elements are connected one after another like this, it is known as a series connection. The output voltage of a series connection of batteries is the total of individual cell voltages, as can be seen from the arrows in the illustrations.

We can build up a battery pack using battery holders or battery boxes readily available in the market. Two such battery holders are shown in figure 2. The voltage available will always be a multiple of 1.5V; 4.5 V with 3 cells, 6 V with 4 cells, 9 V with 6 cells and so on. Today the transistorised equipments do not need very high voltages but when the Transistor technology was still in its infancy, battery packs as large as a shoe box were available, containing 60 or 80 individual cells connected in series and delivered 90 V or 120 V at the output.



Dry Battery Charger

Although the rechargeable accumulators have been with us since long, hobbyists, inventors and scientists have always been interested in inventing a process for charging normal Zinc-Carbon batteries. Even today, no true recharging process exists for this type of batteries. However a part of the emitted charge can be replenished, when the batteries are not strongly discharged. This can substantially increase their service life.

Circuit of recharging

Many of the transistorised equipments like Cassette Recorders, Radios, etc. can be operated from mains as well as batteries. These equipments can be fitted with a few extra components and easily converted to operate in such manner that the built in eliminator of these equipments can replenish the charge of the batteries.

These equipments have a switch (S in figure 1.), which changes over from batteries to the built-in eliminator and vice versa. Mostly this switch is incorporated in the mains socket and is automatically switched from batteries to mains when the mains plug is inserted into the socket.

The modifications to achieve this are shown in figure 2. This requires a resistance R_r and a few diodes D_r .

Components

The batteries can be charged at the most with 1.7V per cell, hence the built-in eliminator voltage cannot be used directly to recharge the cells. If this voltage (U_{NT}) is less than the battery voltage, it is not possible to recharge the batteries. If it is more than $1.7V \times n$ (n =number of cells used) then it must be brought down using diodes D_r .

First the voltage U_{NT} is measured with a multimeter under no load condition. (To achieve this, keep volume control on minimum and switch off the drive motor of the recorder.) The difference between this measured voltage and the value $1.7V \times n$ must be taken up by the diodes, each of them taking up about 0.6V.

Example

A transistor radio with 9V batteries is being modified for recharging. The built-in eliminator output on no load is 11V. The voltage during recharging should not be more than $1.7V \times 6 = 10.2$, which means that the difference of 0.8V must be taken up by the diodes. As one diode can take up 0.6V, we need two diodes in series. Thus 1.2V will be taken up by the diodes and we are left with 9.8V as the recharging voltage, which means a voltage of 1.63V will be available across each cell.

For resistance R_r the generally used values are as given below:

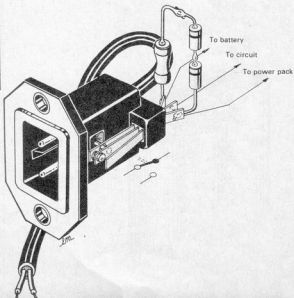
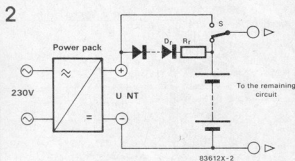
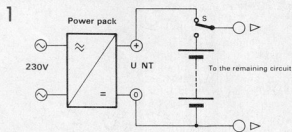
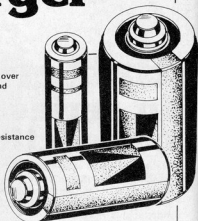
Battery Voltage	Resistance R_r
12V	68 Ω
9V	47 Ω
7.5V	39 Ω
6V	33 Ω
4.5V	22 Ω

Figure 1:

Switch S is used to switch over between mains operation and battery operation.

Figure 2:

Additional diodes and the resistance are soldered between the two switch connections.



Experiments with batteries in series

The following experiments will give you a practical idea of what we have so far studied about batteries in series connection.

The components used in these experiments can be obtained from any electrical goods shop.

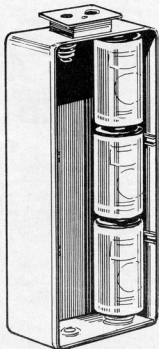
- 1 Battery box suitable for 9V output.
- 1 Torch bulb. (3.6V or 6V)
- 1 Holder for bulb.
- 2 Pieces of insulated copper wire.
- 6 Battery cells to be fitted inside the battery box.

The battery box should be preferably fitted with a detachable end plate, repositioning which converts the box into 6V or 3V battery box.

Before starting the actual experiments, you have to fit the bulb into its holder and connect two pieces of wire to the two terminals on the holder. (Don't forget to remove the insulation from the wire ends!)

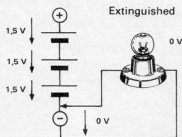
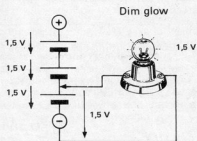
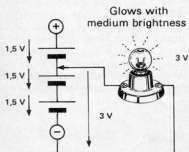
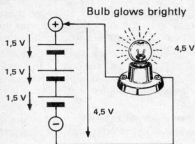
Now to check that the battery cells are in order, touch two poles of any individual cell with the two wires connected to the bulb holder at the other end. Does the bulb light up? Then everything is in order. We can start with our experiments.

1



Inside view of the battery box, with only one row of 3 cells fitted.

2



83607X.2

Four stages of the experiment. Voltage across the bulb is provided by the number of cells in circuit. Brightness of the glow of bulb depends on the voltage available across it.

The battery box has two rows of 3 cells each. For our first experiment we need only one row of three cells. Connect one wire to the minus pole end of the row and second wire to the plus pole end. This covers all the three cells - effectively giving the total voltage of 4.5V available from the series connection of three cells having 1.5V each. The bulb glows brightly.

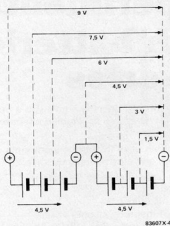
Now, without removing the wire at the minus pole end, touch the other wire to the plus pole of the second cell instead of the third. This time there are only two cells in circuit, giving a total series voltage of 3V. The bulb glows, but not as brightly as before.

Take the wire end away from the plus pole of the second cell and touch the plus pole of first cell with it. The bulb now has a very dim glow. Naturally because the voltage available in the circuit is now only 1.5V.

If you now connect both the wire ends to the minus pole of the first cell, the bulb does not glow at all!

By changing the point at which we tapped the voltage, we were able to get voltages of 4.5V, 3V and 1.5V across the bulb. This time we used only one row of 3 cells from the battery box. If all the 6 cells are fitted into the box, the arrangement is like the one shown in figure 3. Two rows of 3 cells each, connected again in series by the end plate. From this arrangement it is now possible to tap different voltages from 0 to 9V as illustrated in figure 3.

3



QUIZ:

Finally a quiz question for you to solve by trying out.

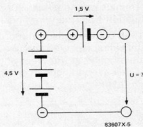
What is the voltage U in the following circuit?

(To try out this circuit, shift the end plate in the battery box forward so that now it can accommodate 4 cells instead of 6.)

Here we have 4 cells in series, but their voltages do not add up to 6V. As one of the cells is connected with reversed polarity, its voltage must be deducted. $1.5 + 1.5 + 1.5 - 1.5 = 3V$

This can also be shown with the bulb, comparing the brightness at each point.

ANSWER:



The Digilex-PCB is now available!

The Digilex-PCB is made from best quality Glass-Epoxy laminate and the tracks are bright tin plated, the track side is also soldermasked after plating. Block schematic layout of components and terminals is printed on the component side.

Price:

Rs. 85.00 + Maharashtra Sales Tax.

Delivery charges extra: Rs. 6.00

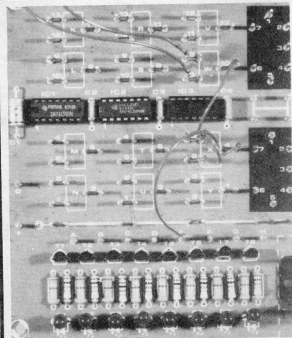
Send full amount by DD/MO/PO.

Available from:

precious[®]

ELECTRONICS CORPORATION

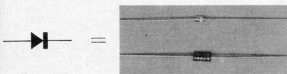
Chhotani Building, 52-C, Proctor Road,
Grant Road (East), Bombay 400 007



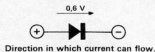
Components

Diodes

Diodes are like one way streets of the electronic circuits. They conduct the current only in one direction.

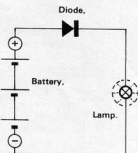


When voltage is applied in such a way that current can flow, a voltage of approximately 0.6 V is dropped across the diode. This value is the threshold voltage of the diode. The two terminals of a diode are known as cathode (represented as bar in the symbol) and anode (represented by the arrow head). Mostly the cathode terminal is marked by a coloured band, a dot on the body or by tapering the shape of the body itself. If the polarity is unknown, it can be tested using a battery cell and a suitable lamp.



The lamp lights if the diode is connected with its anode at the plus pole of the battery and cathode connected to the lamp.

Maximum allowed reverse voltage and maximum allowed forward current are the most important characteristics of a diode to be considered when selecting a diode for a particular application.



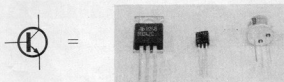
Light Emitting Diodes.

LEDs are encapsulated in a transparent casing and emit light when current flows through them. The threshold voltages in case of LEDs is not 0.6 V like a normal diode but lies between 1.6 V and 2.4 V depending on the type. The current should be between 15 and 25 mA.

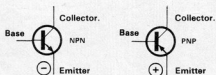


Transistors

Transistors have three leads known as emitter, base and collector. Depending on the construction, the transistor can be NPN or PNP type. In case of an NPN transistor, the emitter should be negative compared to the collector, and in case of a PNP transistor, the emitter should be positive compared to the collector.

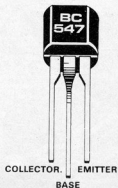


The principle of operation of a transistor is such that a small current made to flow from base to emitter inside the transistor causes a much greater current to flow between collector and emitter which is proportional to the base-emitter current, thus resulting in current amplification. In the SELEX circuits, mostly types BC547 (NPN) and BC557 (PNP) are used, however if these particular types are not available, the following types can be interchanged:



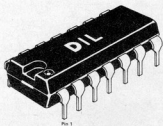
83631X-12

NPN: BC 547,8,9, BC 108,8,9 BC 237,8,9.
PNP: BC 557,8,9, BC 177,8,9, BC 251,2,3.

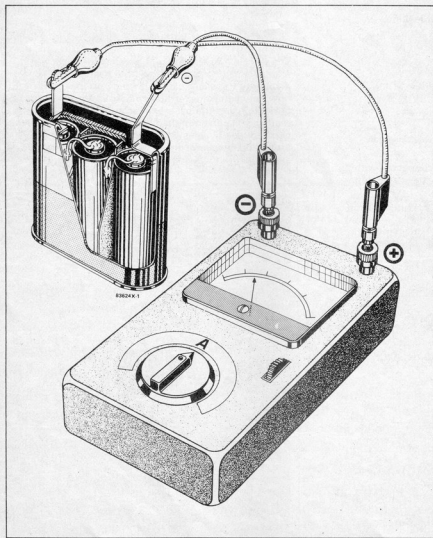


Integrated Circuits.

Today there are so many different types of ICs, that only a few general remarks can be made here. Most of the ICs are moulded in DIL (Dual In Line) casing with two rows of pins. The rows of pins usually stand far apart from each other and must be bent slightly towards the centre line of the IC, before inserting it into a socket. Pin No. 1 is generally marked with a dot or a notch.



Testing batteries with an Ammeter.



Frequently we throw away batteries which may not be really exhausted. When the battery is being used up, its voltage gradually reduces and a stage comes where the battery can supply about 60% to 70% of the rated value. Many electronic gadgets stop functioning at such low voltage levels. The batteries are replaced with new ones and the old cells are thrown into wastepaper basket.

However, these batteries can still be useful for the electronics hobbyist for experimental purposes.

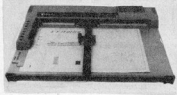
How do you make sure, whether a battery is really exhausted or not? There is no point in measuring the battery voltage with a multimeter, because when no current is being drawn from the battery, even an exhausted cell shows 1 V on the multimeter. The best way is to switch the multimeter on to 2 A or 4 A DC range and test the current supplied by the battery. The reading on the multimeter should be at least 0.5 A. This measurement should be carried out very quickly—otherwise the battery will be exhausted by the test current itself.

A good 1.5 V 'Large' cell should supply about 5A, a 'Medium' cell about 3 A and a 'Pencil' cell about 1.5A.

GRAPHICS PLOTTER

Anika Instruments have successfully developed a new digital graphics plotter. The series 2600 graphics plotters are compatible with almost all micro, mini and mainframe computers. These microprocessor controlled plotters can be used to plot, on paper or film, high precision graphics generated by the computer system.

The series 2600 plotters are high speed plotters with writing speeds of 45 cm/sec. They have the plotting resolution of the order of 0.05 mm per step and a very stable line quality. A built in ASCII character set is provided along with various other graphics capabilities.

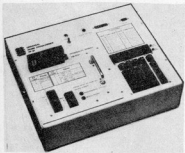


For further information, write to :

Anika Instruments Pvt. Ltd.
24-Housing Society, N.D.S.E. (1)
New Delhi 110 049

UNIVERSAL PROM PROGRAMMER

Professional Electronic Products have developed a Universal PROM programmer PP-81, which is suitable for programming, copying and testing a wide range of PROMs. Additional features like clear RAM, Complement RAM and Partial Programming are also provided. Personality modules suitable for programming EPROM, EEPROM and Bipolar ROMs are available.

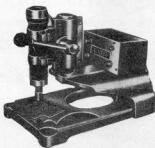


For further information, write to :

Professional Electronic Products,
Post Box No. 316,
Delhi Road,
Meerut 250 002.

PCB DRILLING MACHINE

Elmech PCB drilling machine is a high speed PCB drilling machine which uses no pulleys, gears or belts. It has life lubricated ball bearings for smooth operation and is fully protected against overloads. The design is very compact and can also be operated on a battery. The drilling capacities available from various models are from 0.5 to 2 mm. The machine is suitable for phenolic based as well as glass epoxy boards.



For further information, write to :

Electromech Engineers India
882, Industrial Area A,
Ludhiana 141 003
(Punjab)

DELAY LINES FOR COLOUR TV

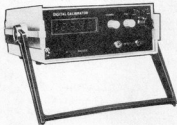
Indian Television Industries offer luminance delay lines for use in colour TV receivers. The standard delay line has a time delay of 330 ns and input/output impedance of 1K ohms. This has 10% tolerance and can be used with chroma decoder IC type TDA 3561. The delay lines can also be supplied in other specifications to meet other requirements against specific order.

For further information, write to :

Diplomat Pvt. Ltd.
49/2, Gurjapal Nagar,
Jalandhar 144 001

DIGITAL CALIBRATOR

A/D/I introduce a digital calibrator for the instrument manufacturers and maintenance departments of the process industries. This unit can measure or feed voltages calibrated in terms of mV or $^{\circ}$ C. In the measuring mode the instrument has very high input impedance and in calibration mode it has a very low output impedance. The range available is 0 to 200 mV. This display is available in LED as well as LCD version, and the instrument can be supplied as portable battery operated unit or as a mains operated unit.



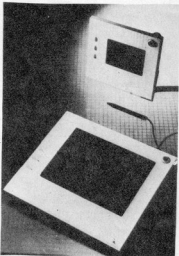
For further information, write to :

Analog and Digital Instrumentation
962, G.I.D.C. Makarpura Industrial
Estate,
Vadodra 390 010

GRAPHIC TABLETS

A new line of graphic tablets has been introduced by Preh. These graphic tablets are adaptable to various graphic

systems and are claimed to be ideal entry devices for a large number of applications.

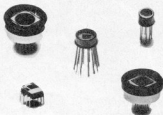


For further information, write to :

Shilpa International,
107, Parklane,
Secunderabad 500 003

UDT PHOTOPS

Photops Hybrid Detector/Amplifier Combinations from UDT, U.S.A. are high speed photodetectors with integral electronics. Their ultrasensitive photodiodes detect light over a wide range of intensities. The built in JFET Op amps allow low level measurements at high speed and ensure low noise output. Applications range from medical diagnostic instrumentation to bar code readers for commercial and industrial use.



For further information, write to :

Toshni Tek International
267, Kilpauk Garden Road,
Madras 600 010.

TOUCH SWITCH

Patron Electronics has developed a bistable touch switch, which can be used to operate any electrical or electronic device with a single sensor. The sensor can be as large as 300 square cm in area. The switch is available as an OEM module or as a complete unit.

For further information, write to :

Patron Electronics
2421, Ghee Walon ka Rasta,
Johari Bazar, Jaipur 302 003

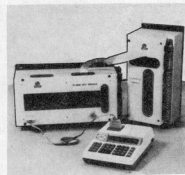
PLANIMETER

Toshni-Tek International have marketed a new Planimeter KP-90 manufactured by Sokkisha Co. Ltd. Japan. This computer planimeter is a precise instrument for fast and accurate measurement of plane areas of any shape and contour. An electro optical shaft encoder which generates 1000 pulses per revolution is used for the basic measurement. The instrument works on rechargeable NiCd batteries and has an auto shut off function when the instrument is not in use for more than 3 minutes continuously.

For further information, write to:
Toshni-Tek International
267, Kilpauk Garden Road,
Madras 600 010

PROGRAMMABLE LOGIC CONTROLLER

Advani-Oerlikon have developed a programmable logic controller based on a single microprocessor chip. This equipment, ADOR PC-4896, is simple to program and easy to operate. It can accept a maximum number of 96 Input/outputs. The ADOR PC-4896 is ideal for use in continuous process plants where there are many applications involving sequence control, firing, interlocking and precise speed control. The equipment finds application in cement, steel, petrochemical, thermal power and paper & pulp industries.



For further information, write to:
Advani-Oerlikon Limited,
Post Box No. 1546, Bombay 400 001.

UNIVERSAL COUNTER

Trans Marketing Pvt. Ltd. have introduced a new universal counter from Racial-Dana.

The instrument has full GPIB programmability, direct frequency measurement to 1.3 GHz and instantaneous nine digit resolution. Single shot time intervals down to a nanosecond can also be measured.

The microprocessor-based design, combined with powerful custom-LSI provide a comprehensive maths capability and a range of special functions. The input conditioning circuits provide maximum flexibility and include a choice of AC/DC coupling, input

impedance, trigger slope and common or separate mode. Amplifiers used have exceptionally flat response and wide dynamic range over the entire frequency band.

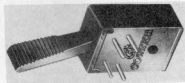
The instruments are available under O.G.L. for R & D laboratories.



For further information, write to:
Trans Marketing Private Ltd.
Sterling Centre,
16/2, Dr. Annie Besant Road
Bombay 400 018.

SUB-MINIATURE TOGGLE SWITCH

'Comtech' T-7 is a sub-miniature PCB mounting toggle switch having overall dimensions of 10 x 7 x 15 mm (excluding lever) and a rating of 125 V at 0.5 Amps. (Resistive) or 0.5 VA at 28 V AC/DC. It is offered with either two positions (change over) or with three positions (with centre-off). The gold plated shoring and bar terminals ensure a faithful operation at low contact resistance of 25 milliohms. Body moulded in ABS plastic is designed to remain away from the PCB to help easy and fast soldering.



For further information, write to:
Component Technique
8, Orion Apartments,
29/A, Lallubhai Park Road,
Andheri (West), Bombay 400 058.

AC TO DC REGULATOR

The MAX 610 family of AC to DC Regulators has been marketed by Malhar Corporation.

These regulators accept 8 V RMS AC input and need only a filter capacitor to make a complete 5 V DC/100 mA regulated power supply. With the addition of a current limiting resistor and capacitor the MAX 610 can directly connect to 110 V to 220 V AC line and give a 5 V DC output.

The MAX 610 family is ideal for applications where size, weight and component count must be reduced. The reliable power up reset and over/under voltage detection makes it

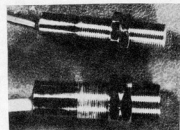
well suited for application in micro-processor based controllers.

For further information, write to:
M/s. Malhar Corporation
43, Wheeler Road
Cox Town, Bangalore 560 005.

INDUCTIVE PROXIMITY SENSOR

TKPS 4XX Inductive Proximity Sensors are non contact, solid state devices. These can be used as direct input interface for Programmable Logic Controllers and other Solid State Logic Systems.

The sensor components are completely sealed in epoxy to resist the effect of oils, coolants, dirt and grime, and have greater resistance to shock and vibrations. The sensor head may be immersed in non corrosive liquids without impairing its operation. Repeat accuracies of over 0.01 mm are available for accurate size control. Sensing distances upto 10 mm can be achieved.



For further information, write to:
Teknix International
2 Bhagat Nivas Bhagat Marg,
Jaipur 302 001.

DIGITAL OHM METER

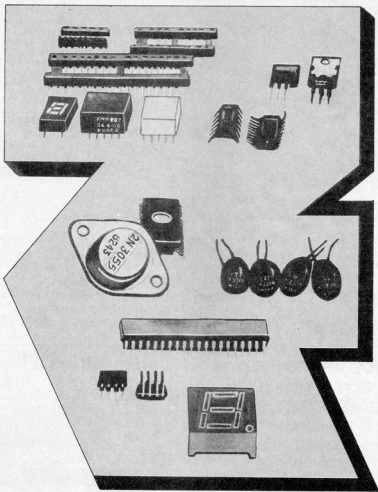
Economy Electronics have introduced a bench type instrument for the measurement of various resistances during manufacturing process of Electrical Heaters, Coils, Relays etc. The instrument is also useful for the inspection, production and R&D departments.

7 segment red LED display is provided for direct reading of the resistance value. Measurement ranges are available from 2 ohms to 2 M ohms in seven steps. Accuracy is $\pm 0.1\%$ of range $\pm 0.1\%$ of reading ± 1 digit.



For further information, write to:
Economy Electronics
15, Sweet Home, Pitamber Lane,
Off Tulsī Pipe Road, Mahim,
Bombay 400 016.

THE SIMPLE ANSWER FOR ELECTRONIC COMPONENTS



EACH NEW DAWN BRINGS THE
POSSIBILITY OF A NEW PROGRESS.

- IC's: TTL, CMOS, MOS, LSI, LINEAR, MICROPROCESSOR, MICRO COMPUTER etc.
- IC SOCKETS: MOLEX & SMK MAKE INCLUDING MOLEX PINS & TEXTOL 'O' INSERTION SOCKETS.
- TRIMPOTS MULTI TURN AS WELL AS SINGLE TURN OF BOURNS, VRN & BAKEMAN MAKE
- DISPLAYS: 3", 5" & 1" IN COMMON CATHOD & COMMON ANODE INCLUDING 3½ DIGIT LCD.
- TANTALUM CAPACITORS OF ALL VALUES, ZENER DIODES, SILICON DIODES, POWER TRANSISTORS, PHOTO TRANSISTORS, PHOTODIODES, LED'S CRYSTAL, etc.

INDENTOR FOR ALL TYPES OF ELECTRONIC COMPONENTS, INSTRUMENTS, GREEN PHOSPHOR AS WELL AS RGB MONITORS ETC.

Our Principles:

M/s. ZIEX TRADING PTE LTD

SINGAPORE/HONGKONG



Zodiac

**ELECTRONICS
CORPORATION**

PUSHPDANT NIWAS
3 CHUNAM LANE
3RD FLOOR, OFF LAMINGTON ROAD
GRANT-ROAD, BOMBAY-400 007

PHONES: OFFICE: 369192 5137225, 5135845

classified ads

ZX 81 users, RAM expansion available. Internal expansion up to 16 K and external RAM pack for 48K memory available. Also available in kit form. Contact: PLS, phone 5618875 or write to P.O. BO 17770 Mulund (W), Bombay-400 080

Available data sheet and application of any electronic components. Minimum charges Rs. 15/- . Write to: DATA BANK, Plot No. 16, Bldg. No. 3, Flat No. 17, Bhavani Nagar, Maral Maroshi Road, Andheri (East), Bombay - 400 059.

For 24 electronic kits as MW Transmitter, Musical horn for scooter or car, Running light (360 Watts) etc. Contact: PERFECT ELECTRONICS 453, Ganapati Ali, Wai - 421803.

Components

are normally available with the following companies:

VISHA ELECTRONICS

17, Kalpana Building,
349, Lamington Road
Bombay - 400 007 Phone: 362650

DYNALOG MICRO SYSTEMS

14, Hanuman Terrace,
Tara Temple Lane,
Lamington Road
Bombay - 400 007. Phone: 353029, 362421

ELEKTROKITS

20, Narasingapuram Street
(First Floor) Mount Road
Madras - 600 002

INTEGRATED ELECTRONICS INSTRUMENTS

8-2-174 Red Cross Road
Secunderabad 500 003 Phone: 72040

Advertisers Index

APEX	9.28
BALAJI	9.26
COMPONENT TECHNIQUE	8.16
CONNECTRONICS	8.11
DEVICE ELECTRONICS	8.09
DOMINION RADIOS	9.26
DYNALOG	9.40
ELCIAR	9.30
ELCOM	9.33
ELECTRICAL INSTRUMENT CO.	8.14
ELECTRO MICRO COMPUTER	9.35
ELECTRONICS UNLIMITED	9.33
ELECTRO SYSTEM	9.35
GENERAL INSURANCE	8.17
GRAPHICA DISPLAY	8.14
HIOKI	8.10
IEAP	9.28
INDUSTRIAL RADIO HOUSE	8.13
INSTRUMENT CONTROL	9.35
ION ELECTRICALS	9.30
JETKING	9.28
LEONICS	9.34
LUXCO	9.2.9
MACMILLAN INDIA LTD	8.08
MICROSIGN PRODUCTS	8.06
OSWAL	9.32
PADMA	8.14
PARVAIL ELECTRONICS	8.06
PEARL ELECTRONICS	9.34
PLA	9.27
PRECIOUS	9.36
PULSAR	9.34
PULSECHO	8.08
ROCHER	8.16
SAINI ELECTRONICS	9.26
SCIENTIFIC MES TECHNIQUE	8.08
SOLDRON	8.10
TARGET MARKETING	8.06
TECHNOMATIC	8.02
TEXONIC	8.16
UNLIMITED ELECTRONICS	8.07
VASAVI	8.15
VISHA	9.39
ZAC ELECTRONICS	9.33
ZODIAC	9.25

missing link

RLC meter

(March 1985, p. 3-50)

If the oscillator frequency differs appreciably from the stated value, the number of turns of L_8 may be altered; for instance, if the measured frequency is 36 kHz, whereas 18 kHz is desired,

$$L_{8a} = 36/18 \times 50 = 100 \text{ turns}$$

$$L_{8b} = 36/18 \times 10 = 20 \text{ turns.}$$

It is not always possible to adjust the offset with P_2 in a way where both LEDs go out; in that case, adjust P_2 as close as possible to the change-over point. This applies also to the adjustment of P_1 during measurements.



The scale division of P_1 shown in figure 5 must be taken primarily as an example, because the capacitance scale, in reality, is not linear, but accords to a $1/x$ function. If S_4 is replaced by a 3×4 or 4×3 position switch, the scale division may be made linear — see accompanying

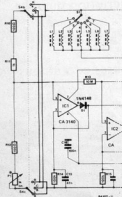
Digilex

(June 1985 page 6.58)

The following items should be added to the list
C8 - 1000 $\mu\text{F}/25\text{V}$.
C8-7805 (5V regulator)
should be read as
IC 8-7805 (5V regulator)

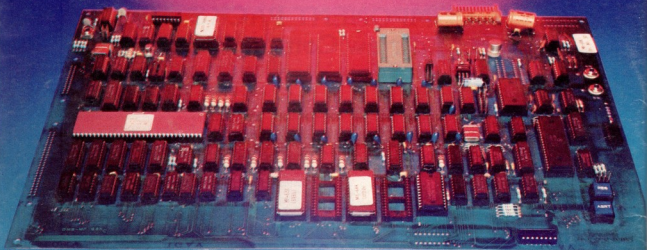


figure. The scale division for C is then, as that for R and L , clockwise. It remains advisable to calibrate the scales separately.



Dynalog's Leadership

in 8 and 16 Bit Microprocessor training/development kits....
is only a part of the Dynalog Success Story!



Another First

MICROFRIEND-68K 16/32 Bit

Microprocessor training/development kit
Continues the tradition of Dynalog's Leadership

MICROFRIEND-68K Highlights:

- 68000 CPU operating at 8 MHz. ■ 20K FIRMWARE with single line assembler and disassembler. ■ 128K Dynamic RAM. ■ Onboard EPROM Programmer for 2716, 2732, 2764, 27128. ■ Video Controller using MC 6845 CRT Controller Chip. ■ RS 232C Serial Port with complete baud rate control. ■ Centronics compatible Printer Port. ■ Audio Cassette I/F with file management. ■ ASCII Keyboard I/F. ■ 40 I/O lines and 3 timers (16 bit) available on connectors. ■ Detailed informative documentation.

Manufactured by:

DMS Dynalog
Micro-Systems

14, Hanuman Terrace,
Tara Temple Lane,
Lamington Road, Bombay 400 007.

Tel: 353029, 362421
Telex: 011-75614
Gram: ELMADEVICE

Sales Representatives :-

TECHNICS, 4731/21 Dayanand Road, Daryaganj, NEW DELHI-110 002. Tel : 276988

ELECTRO ENGG. ENTERPRISES, 136, 1st Flr., Kabra Complex, M. G. Road,
SECUNDERABAD-500 003 Tel : 822467